

**PLAN VIEW**

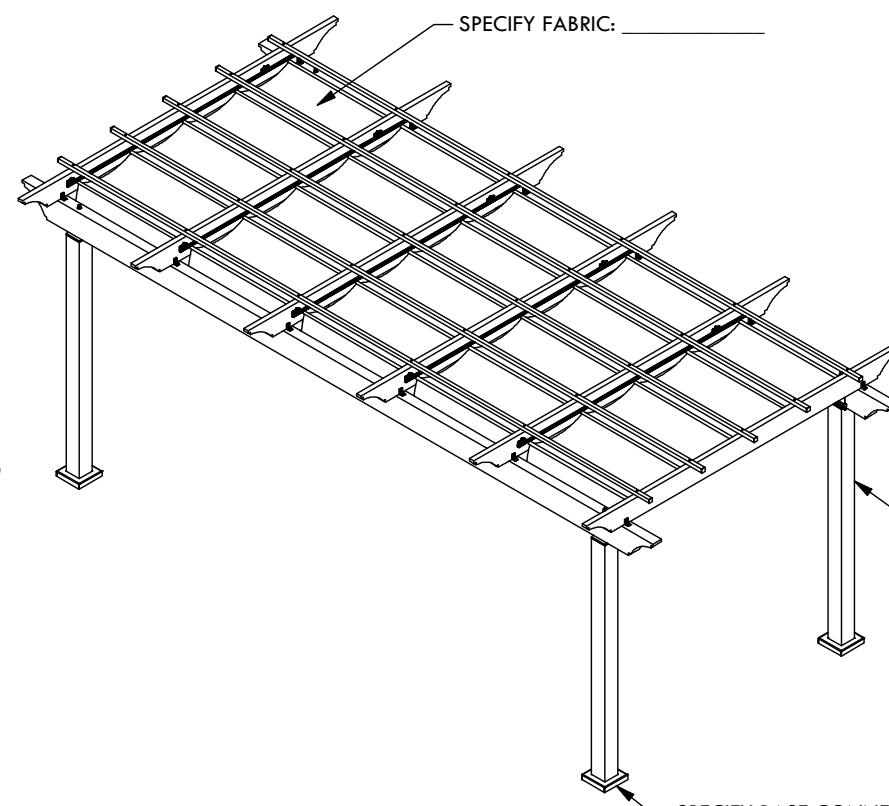

- SPECIFY FINISH:**
- SANDSTONE
  - SEASHELL WHITE
  - GREY
  - STATUARY BRONZE
  - JET BLACK

- SPECIFY BASE CONNECTION:**
- CONCRETE MOUNT
  - FRAMING MOUNT

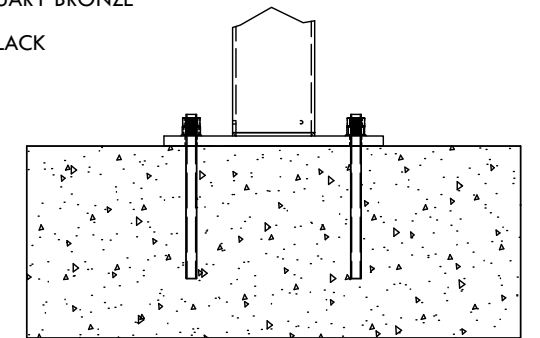

**CONCRETE MOUNT**

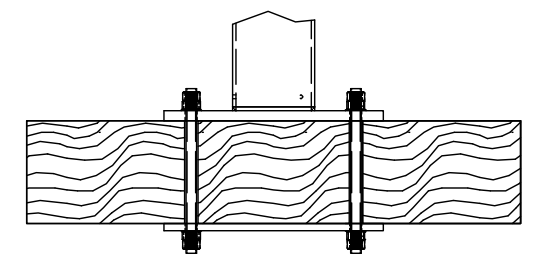

**FRAMING MOUNT**

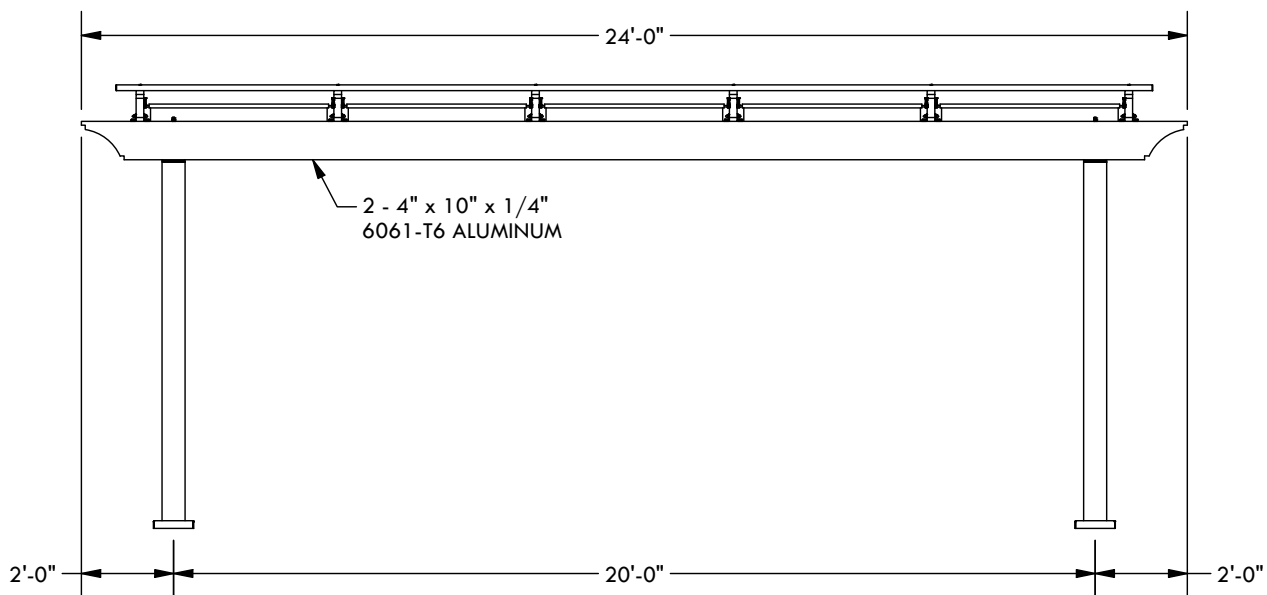

**WIDTH ELEVATION**

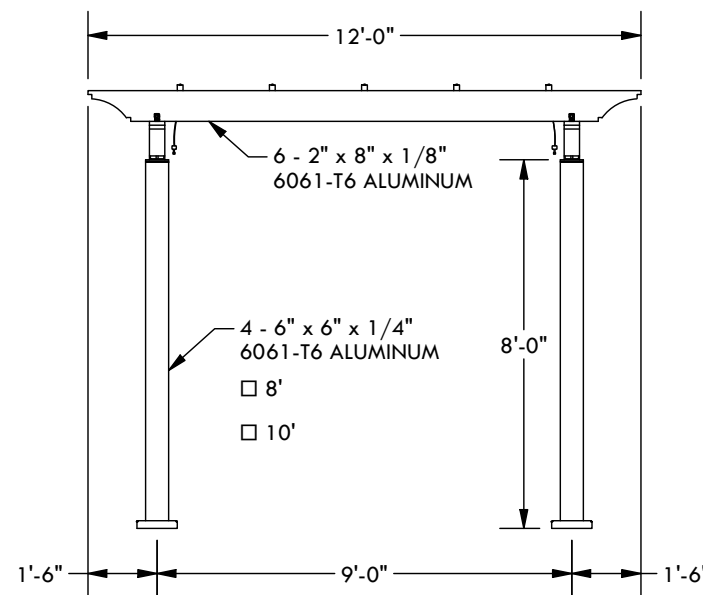

**PROJECTION ELEVATION**

DESCRIPTION			
<b>24' WIDE X 12' PROJECTION FREESTANDING ATLAS</b>			
REV	BY	DESCRIPTION	DATE
	CL	INITIAL RELEASE	1/13/2026

© 2026 Structureworks

**STRUCTUREWORKS™**

www.structureworks.com 877.489.8064