

Artisan-LS Installation Guide

Read this guide before beginning installation.

All packages should be opened and inspected for hidden damage upon receipt. Any missing or damaged components should be noted on the delivery receipt with the carrier before accepting the shipment. All items should be repackaged and stored where protected from moisture, dirt, and excessive heat. Do not wrap material so that heat or moisture can become trapped. Ensure that items are level, fully supported, and have airflow between parts. Damage from improper storage is not considered shipping damage and is not covered by product warranties. Handle materials so as to protect materials, coatings, fabric and finishes during transportation and installation to prevent damage or staining.

It is the responsibility of the installer to meet or exceed all code and safety requirements, and to obtain all required building permits. These instructions are only a guide, and may not address every circumstance. The installer should determine and implement appropriate installation techniques for each situation. Structureworks shall not be held liable for improper or unsafe installations.

Recommended Tools & Required Materials

The tools required will vary depending on the canopy configuration and the installation surface. Additional materials such as attachment hardware, flashing, and silicone caulk may be needed.

All installations:

- Pencil
- 4' Level
- Ladder (2)
- Framing Square
- Hammer
- Needle Nose Pliers
- Adjustable Wrench
- Tape Measure
- Drill
- Impact Driver w/ Bits
- Socket Wrench w/ Extension & ½" Socket
- Caulk Gun
- Silicone Caulk
- Prebent Flashing

Wood mount installations:

- ¼" Drill Bit for Wood
- ¾" Lag Bolts

Masonry mount installations:

- ½" Drill Bit for Masonry
- Hole-Cleaning Brush
- Compressed Air
- ½" Masonry Anchors

Cleaning and Maintenance

Use a combination of Simple Green All-Purpose Cleaner and hot water with a soft bristle brush. Clean after installation and on an annual basis. For more difficult to clean marks, a Mr. Clean Magic Eraser can be used. Structural attachments should be inspected annually.

Planning - Masonry Mount

Find the location where the canopy is to be installed and review the attachment locations on page four to ensure there are no obstructions and that all structural attachments will be in locations where the building can support them.

For concrete or masonry installations, drill holes for the installation of masonry anchors following the manufacturer's instructions.

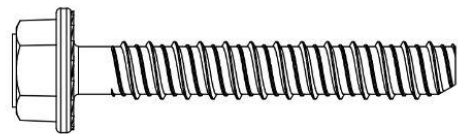
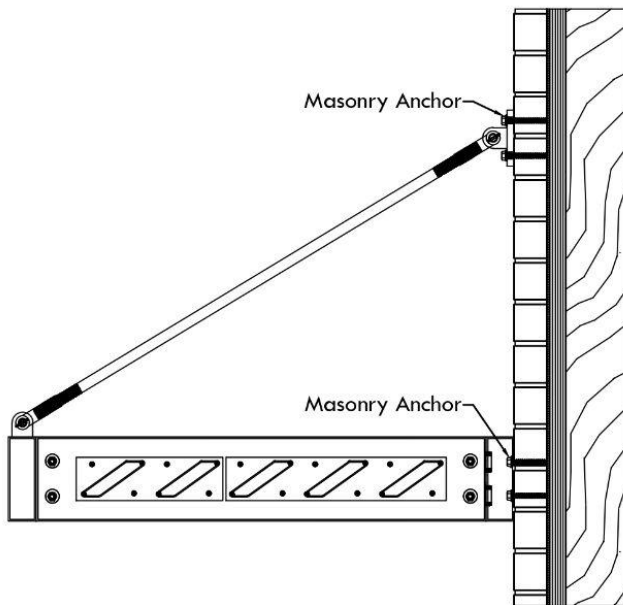
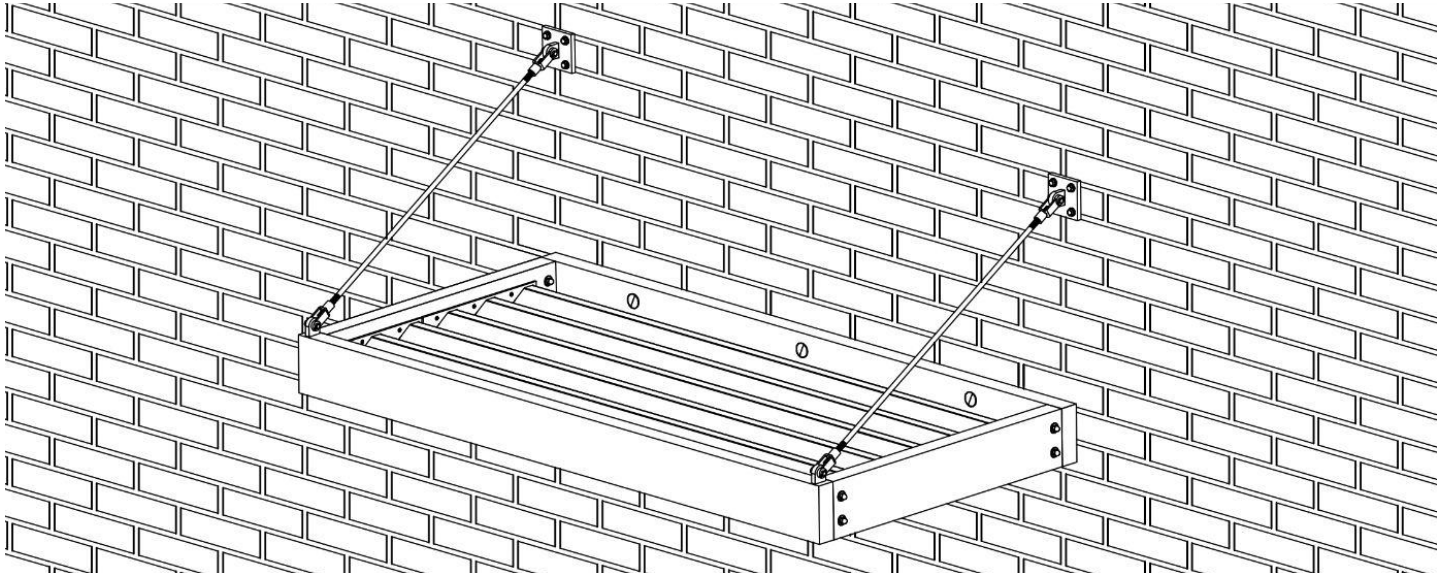

Planning - Wood Mount

Find the location where the canopy is to be installed and review the attachment locations on page four to ensure there are no obstructions and that all structural attachments will be in locations where the building can support them.

For wood installations, drill pilot holes for the installation of lag screws.

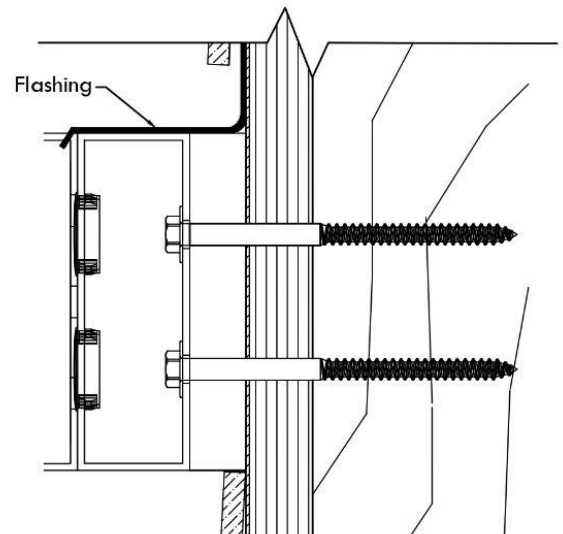
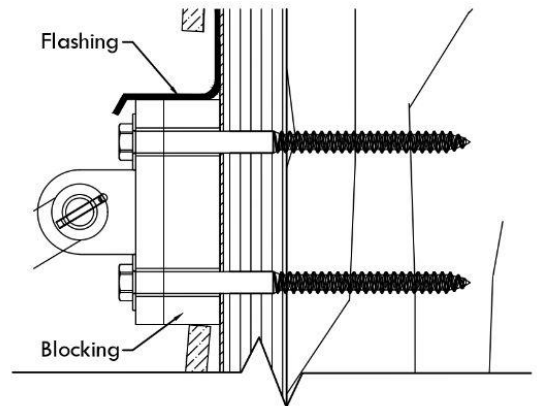
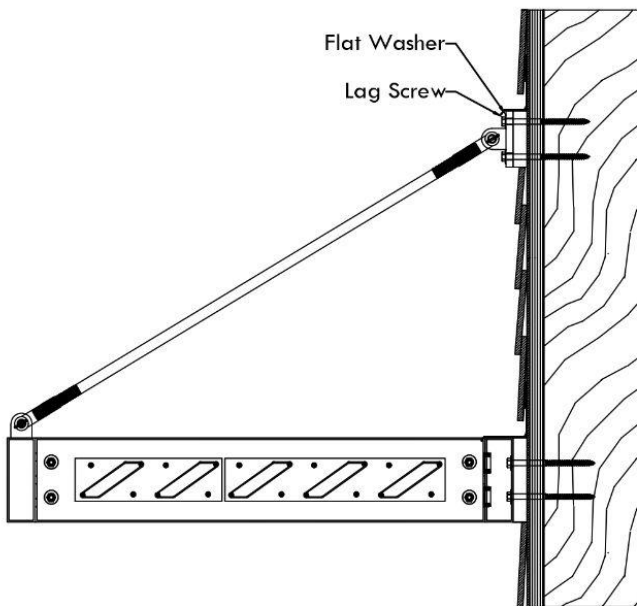
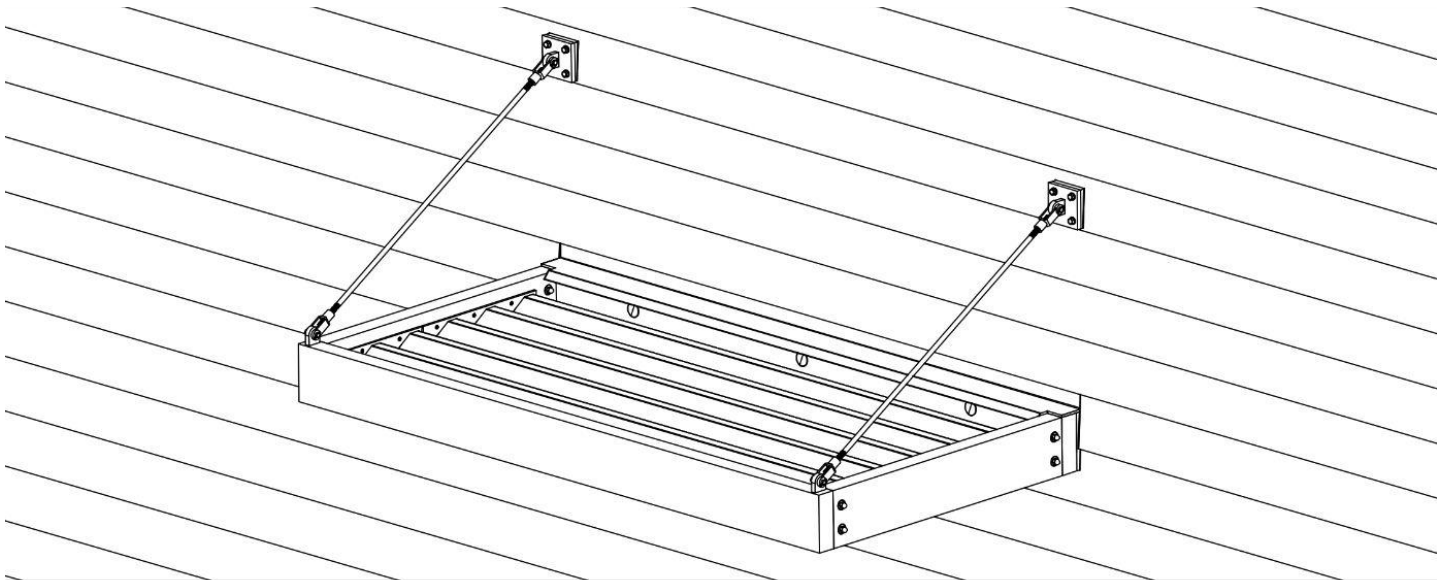

Layout

Using the table below, layout the ledger and tie back mounting plate locations on the wall. Use the ledger and a tie back mounting plate as templates to mark the center locations for each hole. Check that all hole locations are correct and that the mounting locations for the ledger and two tie back mounting plates are correctly spaced from one another.

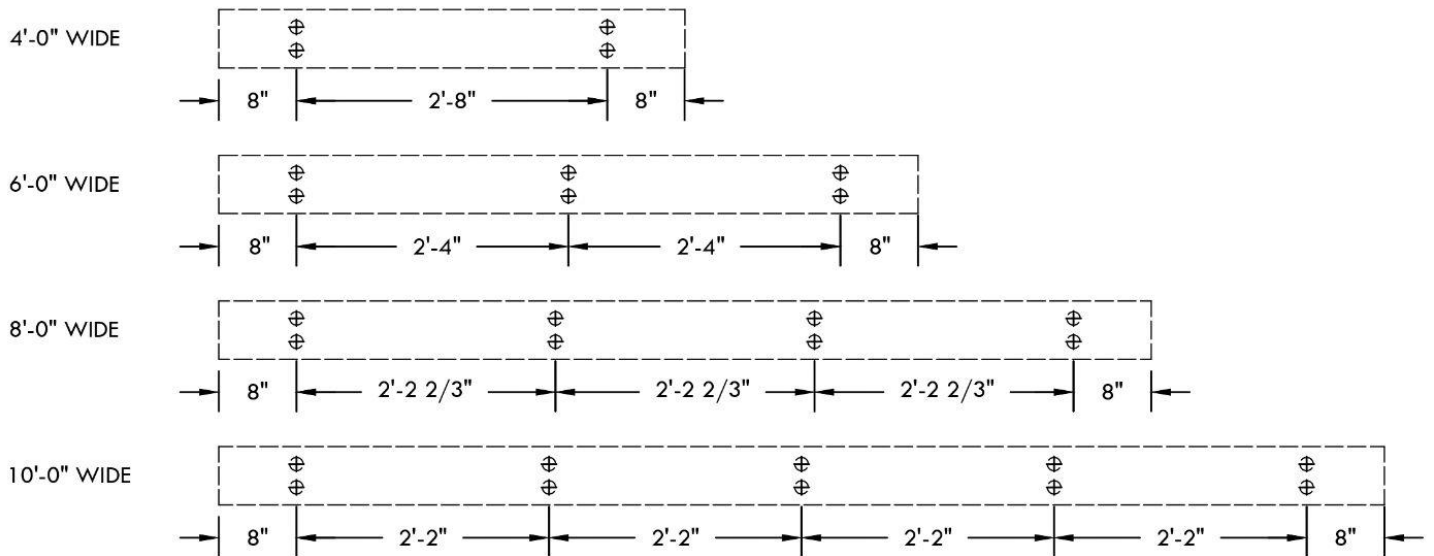
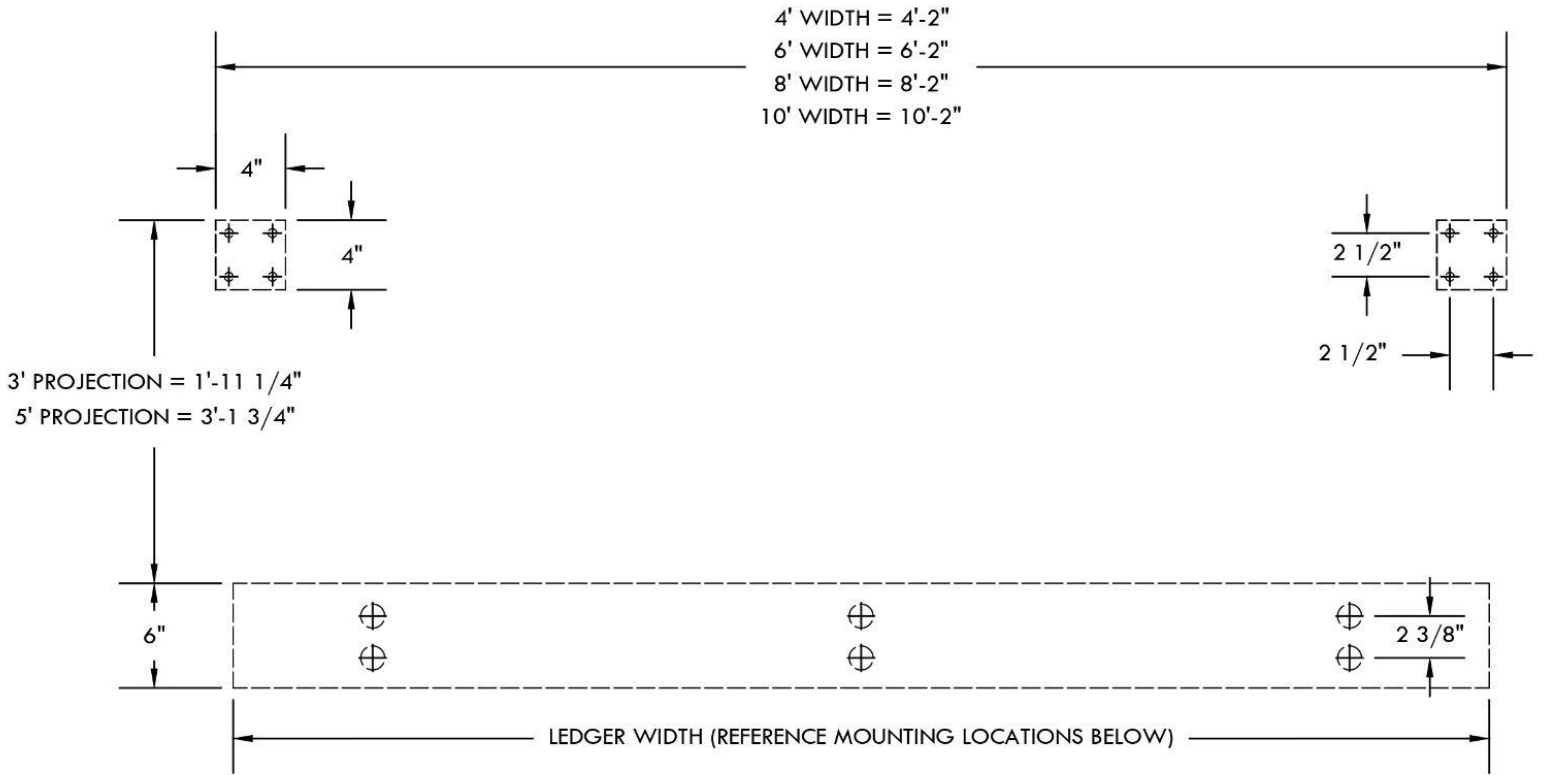

Install Tie Back Mounting Plates

Drill $\frac{3}{8}$ " holes for wood mount installations with lag screws or $\frac{5}{8}$ " holes for masonry anchors. Install the tie back mounting plates using lag screws for wood attachment or masonry anchors for brick or concrete attachment.

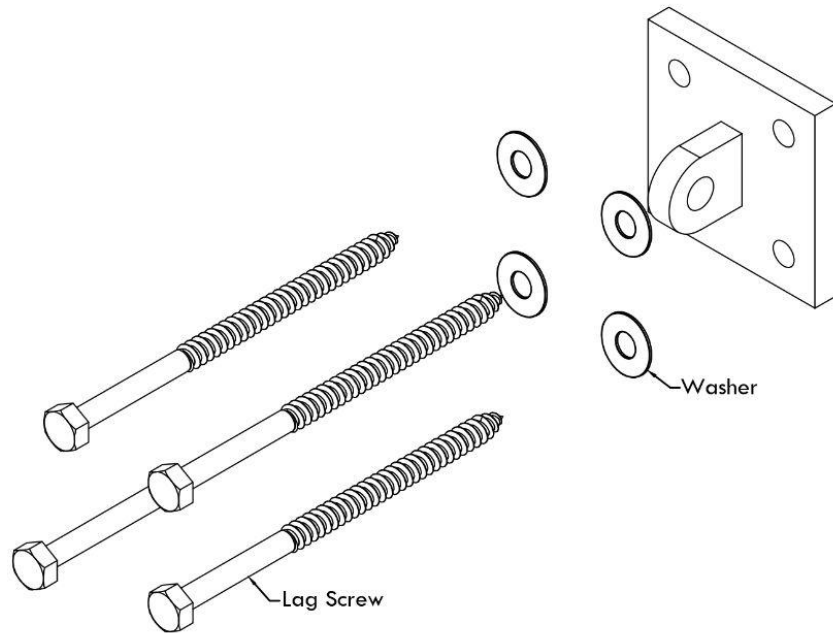

Install Ledger

Drill $\frac{3}{8}$ " holes for wood mount installations with lag screws or $\frac{5}{8}$ " holes for masonry anchors. Install the ledger using lag screws for wood attachment or masonry anchors for brick or concrete attachment.

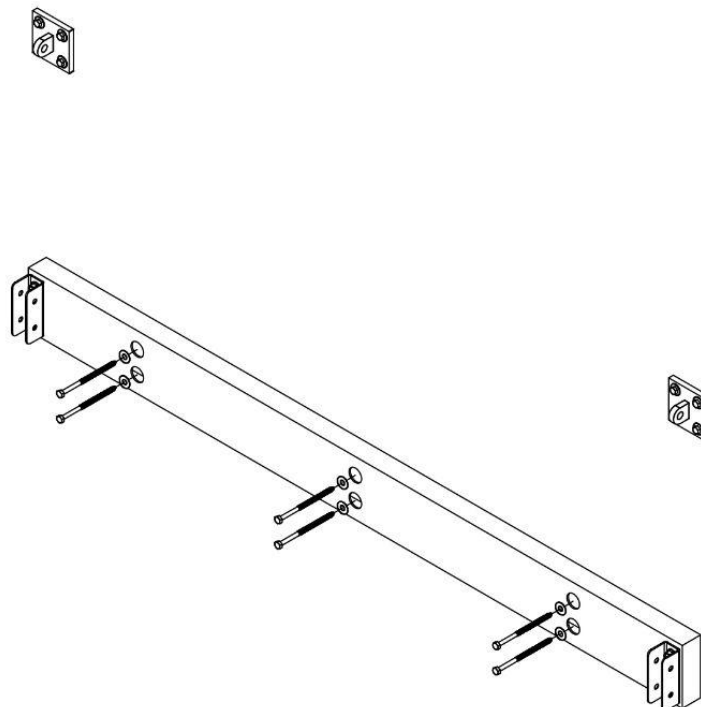

Install Tie Backs

Install the tie backs by placing the clevis fork around the mounting plate tab, next place the clevis pin through the clevis fork and mounting plate tab. Insert two cotter pins to retain the clevis pin. Bend the cotter pin legs with needle nose pliers so that the cotter pins are permanently secured. Repeat this process for the second tie back.

Check the length of both tie backs to ensure that they will support the front beam at the same height and parallel to the ledger. The length of the tie back can be adjusted by turning the clevis fork on the tie back.

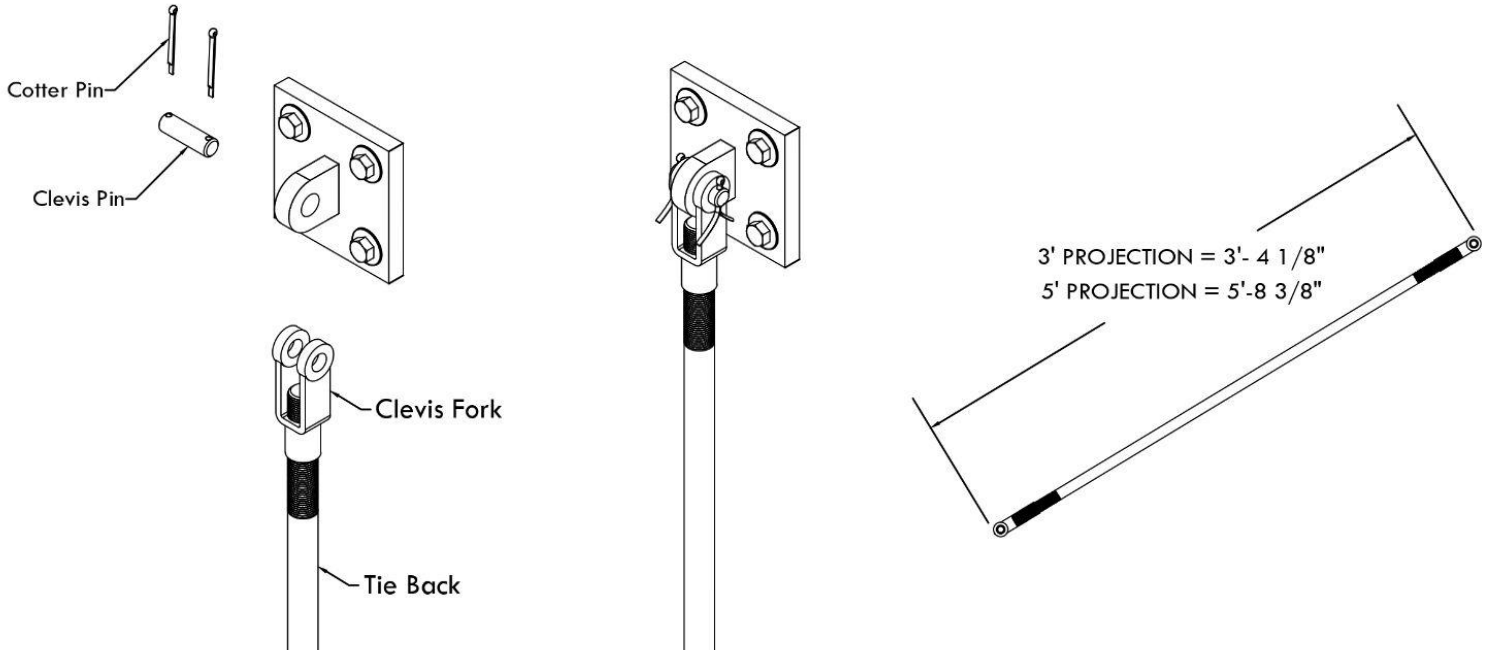

Install Front Beam

Lift the front beam to the clevis forks on the bottom of the tie backs. Place the clevis forks around the tabs on the front beam, next place clevis pins through the clevis forks and tabs. Insert two cotter pins to retain each of the clevis pins. Bend the cotter pin legs with needle nose pliers so that the cotter pins are permanently secured.

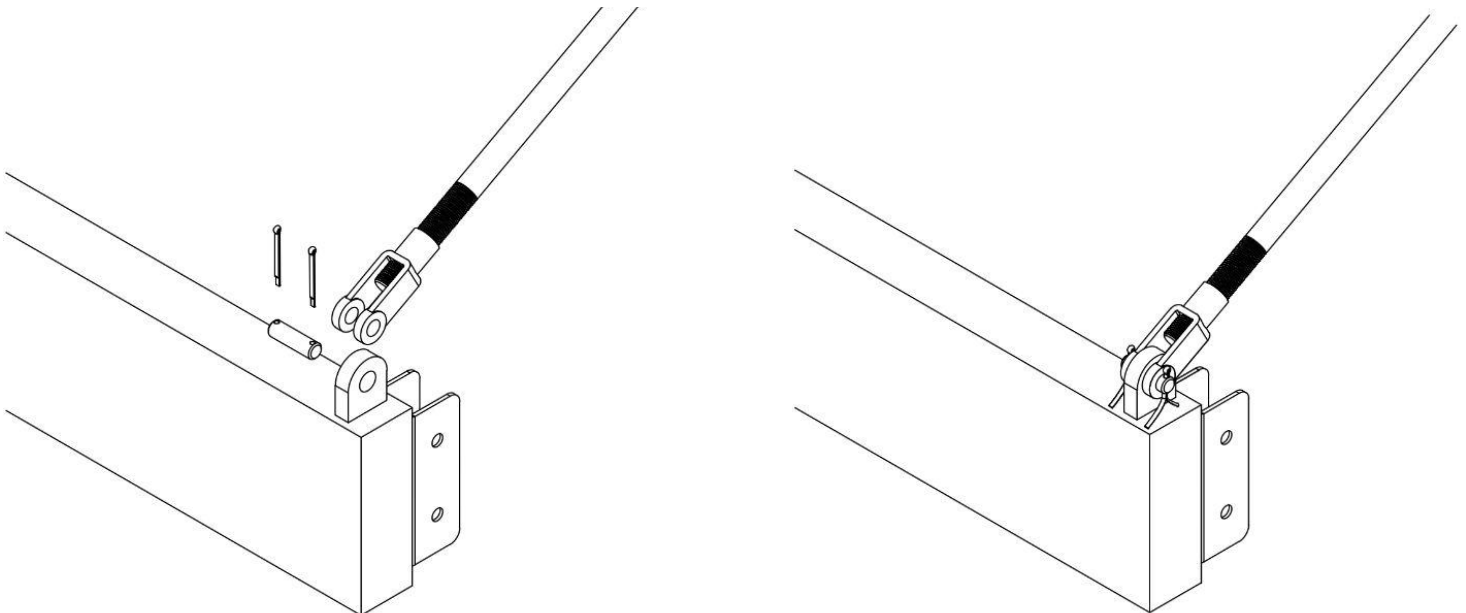

Install Side Beams

Lift the front beam and install both side beams over the brackets on the front beam and ledger. Secure the side beams with threaded rods, flat washers, and acorn nuts. Ensure that the finished frame is level and perpendicular to the supporting wall.

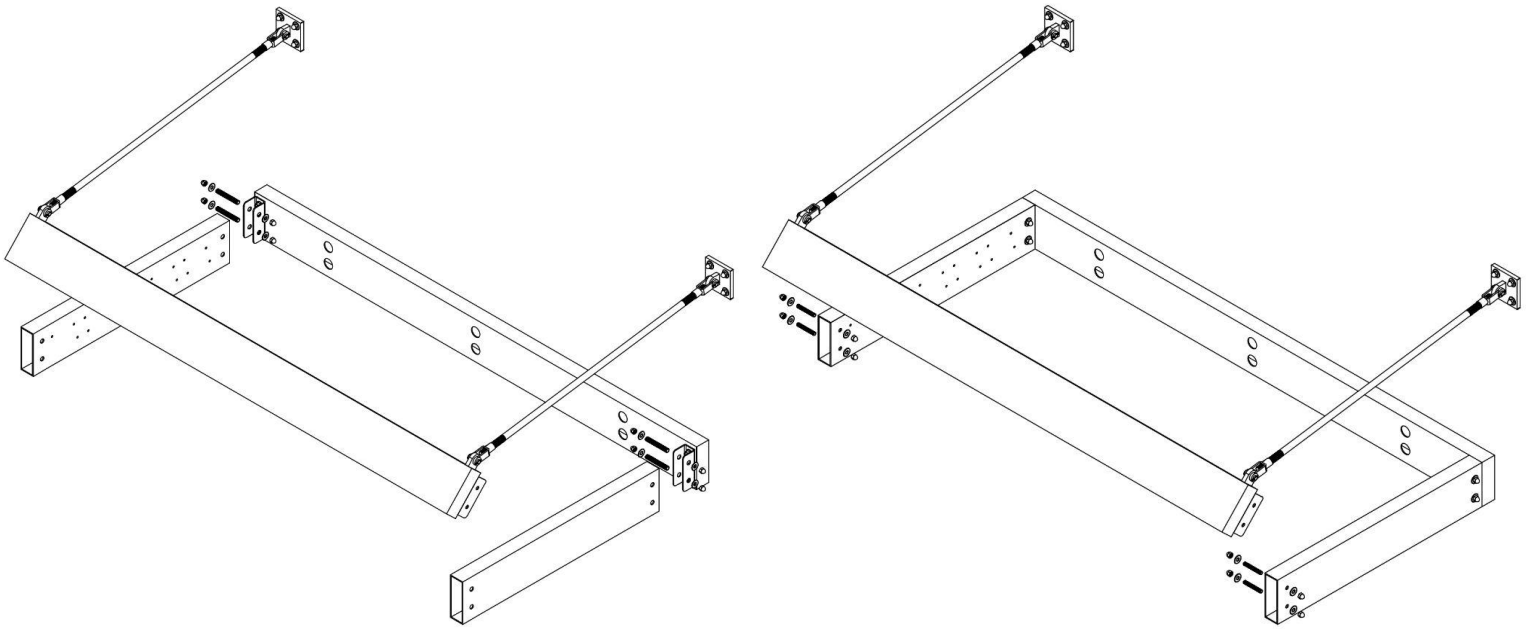
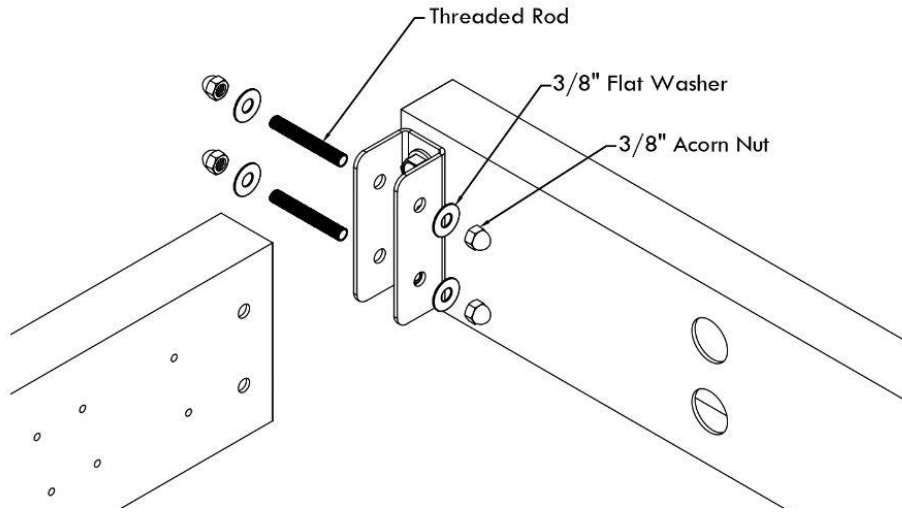

Assemble Louvers

Position a louver mounting plate at the end of the louvers and secure with screws. Repeat this process on the opposite end of the louvers. Repeat this process until all louver assemblies are built.

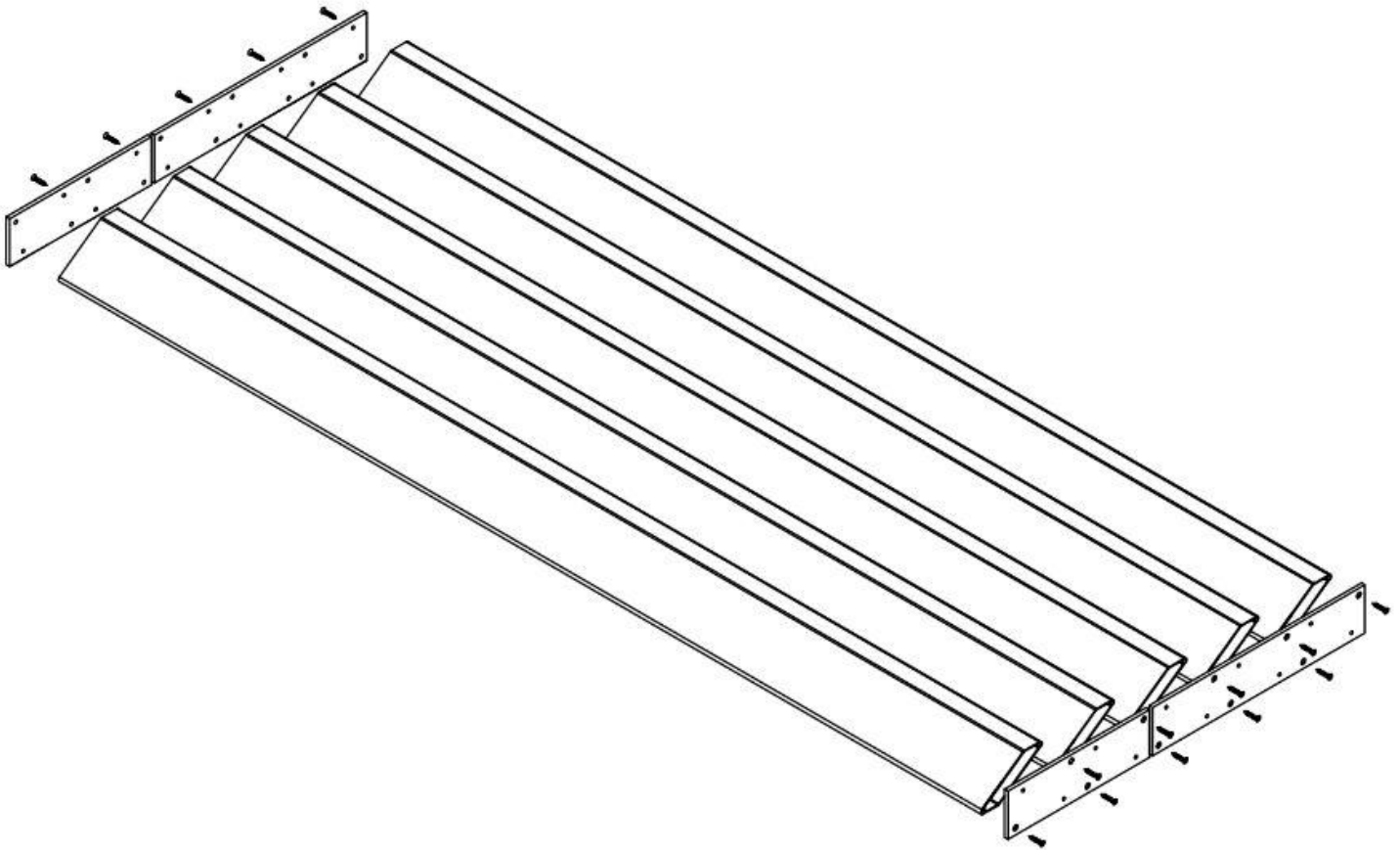
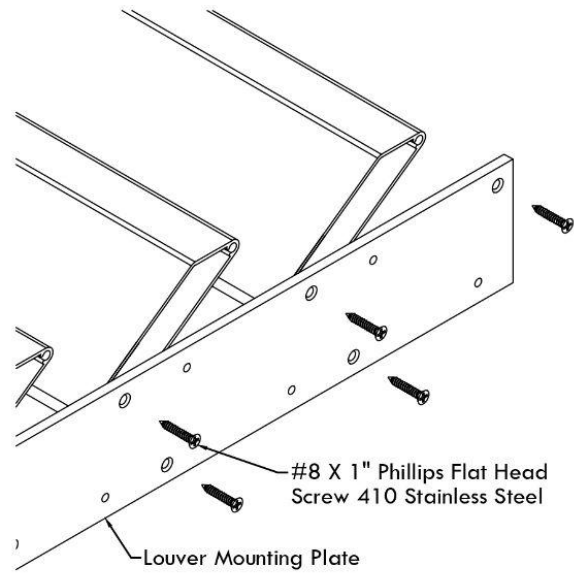

Install Louver Assemblies

Raise one louver assembly into place inside of the canopy frame. Secure the louver assembly with screws into both sides of the canopy frame. Repeat this process for the remaining louver assembly.

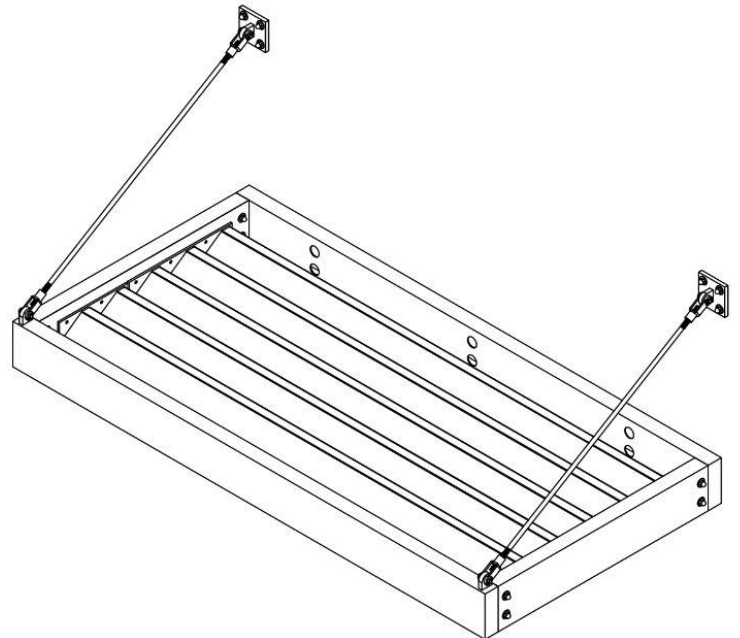
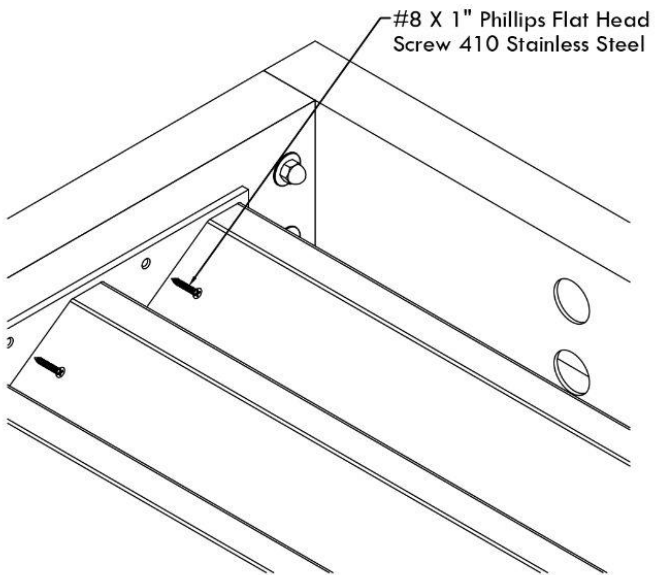
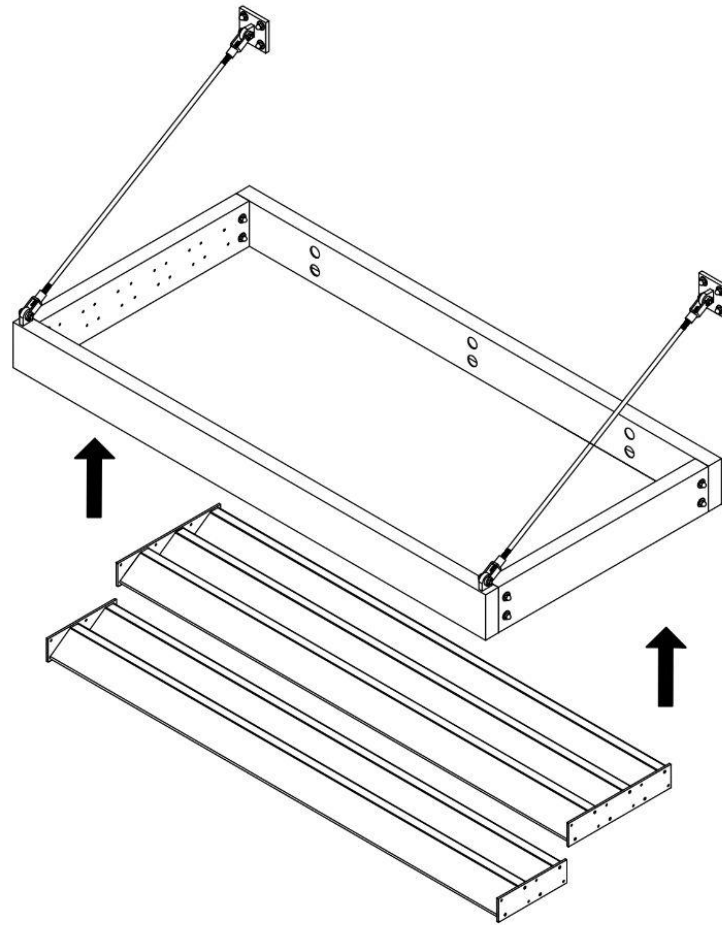

Install Hole Plugs

Install hole plugs into the ledger.

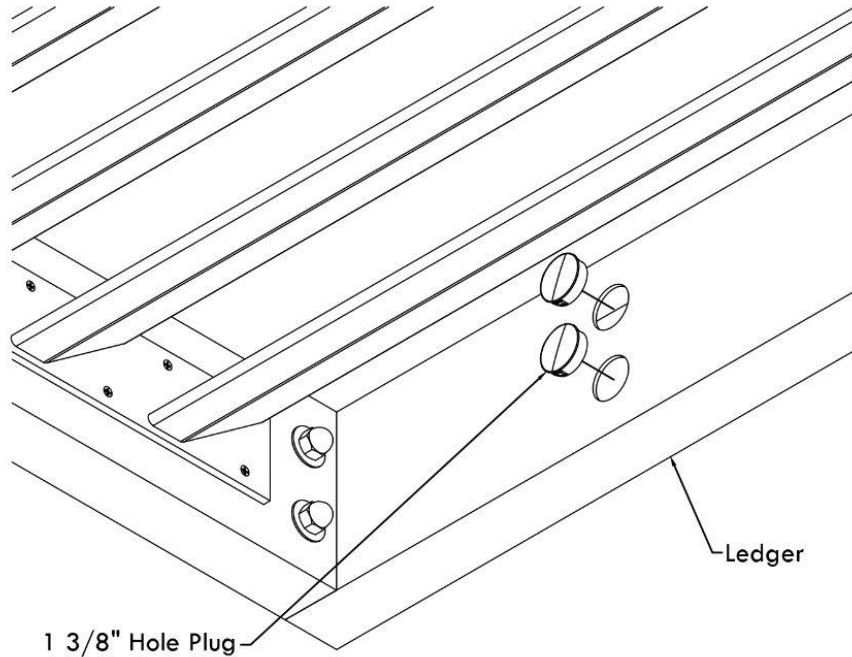

Paint Touch-Up

Canopies may require touch up over time and at completion of construction. Use extreme care when handling components to avoid scuffs and scratches. Touch up paint is provided. In the event of scratching or chipping, touch up the painted surface with the included brush. Apply light coats in order to allow the paint to flow and dry with a smooth finish.