

SPECIFY FINISH:  
 BASE PANEL/FRAME \_\_\_\_\_  
 TOP PANEL \_\_\_\_\_

SPECIFY WIDTH:  
 4'-0"  
 6'-0"  
 8'-0"  
 10'-0"  
 CUSTOM \_\_\_\_\_ (MAX 10'-0")

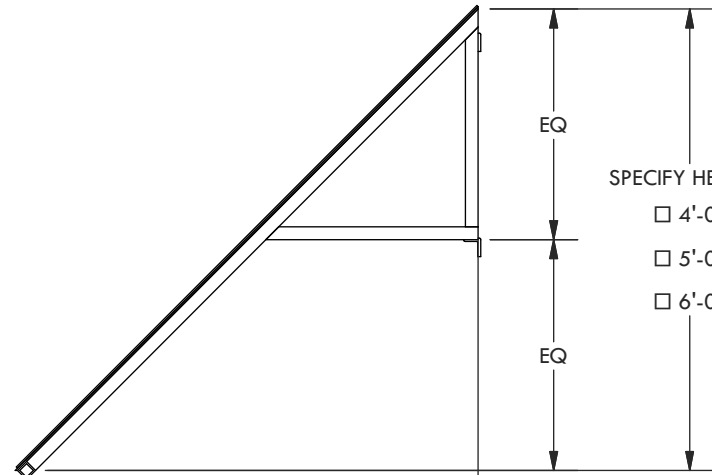

SPECIFY HEIGHT:  
 4'-0"  
 5'-0"  
 6'-0"

SPECIFY PROJECTION:  
 2'-0"  
 3'-0"  
 4'-0"  
 5'-0"  
 6'-0"

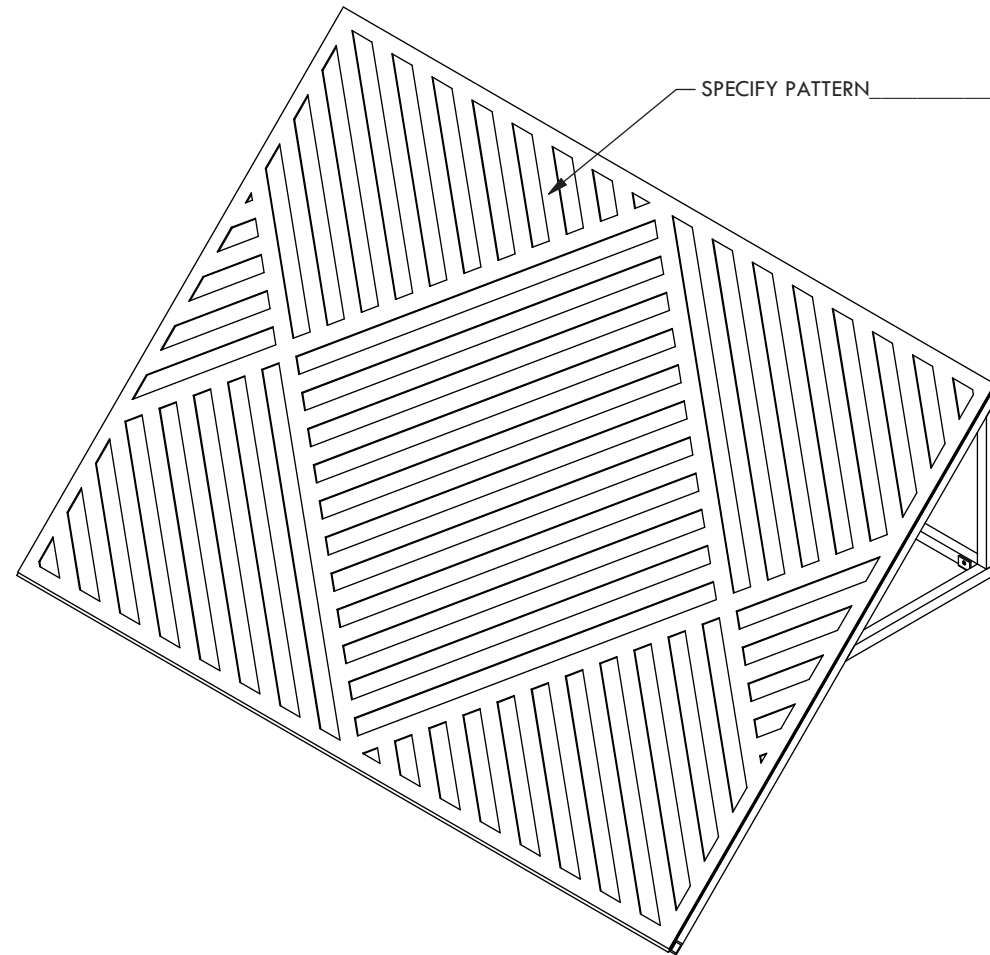

SPECIFY PATTERN \_\_\_\_\_

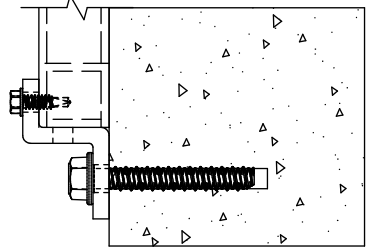
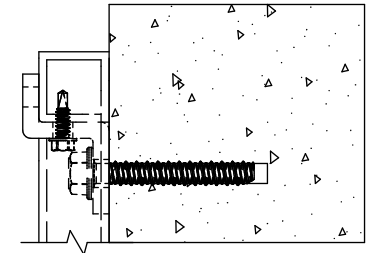

WALL CONNECTION  
 CONCRETE

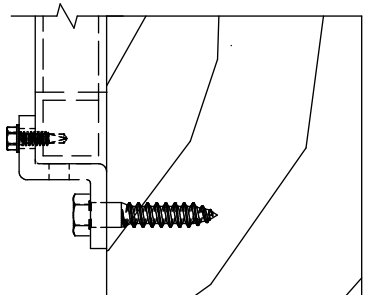
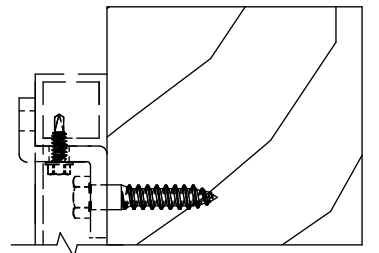

WALL CONNECTION  
 WOOD FRAMING

DESCRIPTION			
<b>UMBRA AC450P</b>			
REV	BY	DESCRIPTION	DATE
	SP	INITIAL RELEASE	02/23/24

© 2024 Structureworks

**STRUCTUREWORKS™**

www.structureworks.com 877.489.8064