

## Solare Installation Guide

Read this guide and review shop drawings and notes before beginning installation.

All packages should be opened and inspected for hidden damage upon receipt. Any missing or damaged components should be noted on the delivery receipt with the carrier before accepting the shipment. All items should be repackaged and stored where protected from moisture, dirt, and excessive heat. Do not wrap material so that heat or moisture can become trapped. Ensure that items are level, fully supported, and have airflow between parts. Damage from improper storage is not considered shipping damage and is not covered by product warranties. Handle materials so as to protect materials, coatings, fabric and finishes during transportation and installation to prevent damage or staining.

It is the responsibility of the installer to meet or exceed all code and safety requirements, and to obtain all required building permits. These instructions are only a guide, and may not address every circumstance. The installer should determine and implement appropriate installation techniques for each situation. Structureworks shall not be held liable for improper or unsafe installations.

### Recommended Tools

The tools required for installation will vary depending on structure configuration and the hardware used. Review shop drawings to confirm drill bit sizes, socket sizes, and other project specific tools.

- Pencil
- 4' Level
- 8' Ladder (2)
- Framing Square
- Hacksaw/Bolt Cutters
- Caulk Gun
- Impact Driver w/ Phillips Bit
- Adjustable Wrench
- Tape Measure
- Socket Wrench w/ Deep Sockets
- Drill
- Circular Saw w/ Abrasive Blade
- Compressed Air
- Hole-Cleaning Brush

### Required Materials

Depending on the configuration of the structure, additional materials such as ledger attachment hardware, silicone caulk, and anchoring epoxy may be needed. Review shop drawings for project specific requirements.

### Cleaning and Maintenance

Use a combination of Simple Green All-Purpose Cleaner and hot water with a soft bristle brush. Clean after installation and on an annual basis. For more difficult to clean marks, a Mr. Clean Magic Eraser can be used. Structural attachments should be inspected annually.

## Installation Sequence

This installation guide provides a step by step sequence for the installation of the structure. This guide covers only the structure, separate installation guides are provided for accessories and other products used in the installation of the structure. Ensure that you have all required installation guides before beginning the installation.

All structures are made to order and are provided with shop drawings. Shop drawings may contain additional information, details, or job specific instructions. Shop drawings take precedence over this installation guide.

## Layout and Install Columns

Layout all columns according to the shop drawings. Columns must be located precisely and variations in the height of the mounting surface must be accounted for by trimming or leveling each column. The structure will not install correctly if the columns are installed out of square or out of level from one another. Refer to Fiberglass Column Installation Guide for more information.

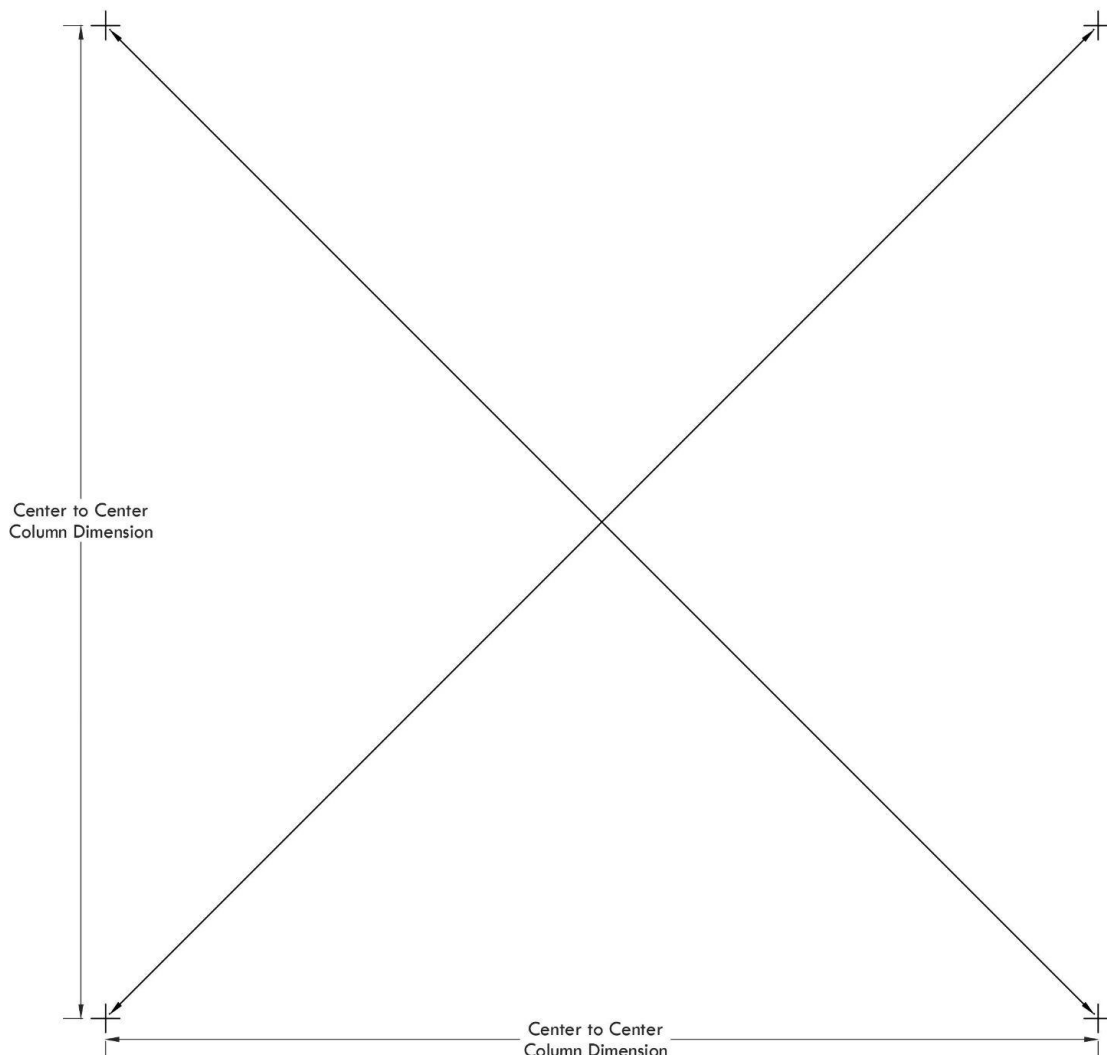

## Install Brackets and Beams

Mark the rafter center locations on the tops of all beams. Install rafter brackets with screws. Place the beams on top of the columns and secure to the double beam adapter with screws.

If the structure includes any integrations such as lighting or wiring for fans or heaters, make any connections or chase any wires and test the connections before installation of the beams.

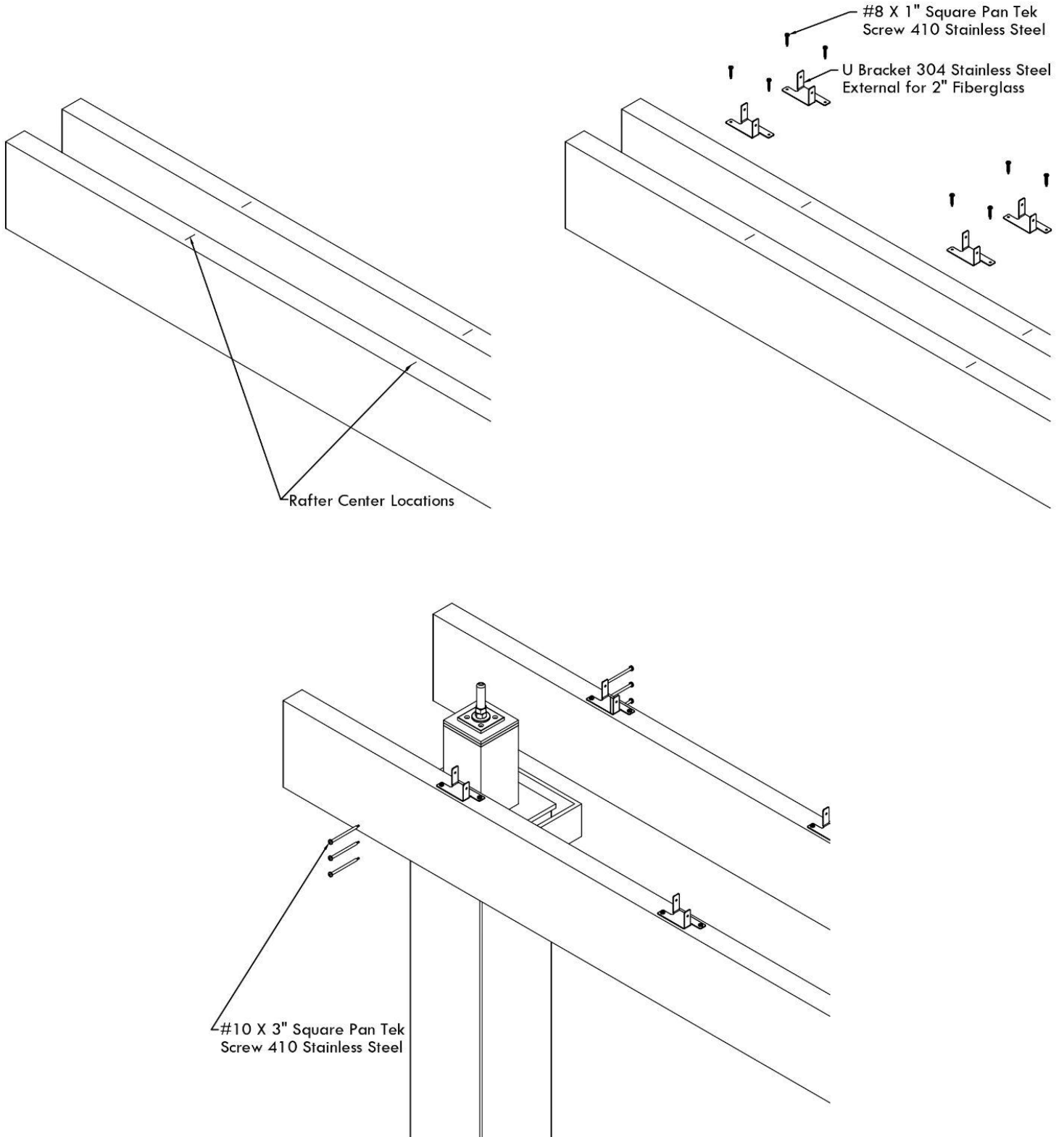

## Install Brackets and Ledger - Attached Structures Only

Install the internal brackets for the rafters and side fascia on the ledger with screws. Mount the ledger to the host structure. Ensure that the ledger is mounted to structural components that can support the loads of the structure. Hardware for ledger attachment is not provided and will vary depending on mounting conditions. Hardware can be installed through the face of the ledger and left visible or access holes may be drilled on the face of the ledger so that the hardware can be installed inside of the ledger and hidden from view once hole plugs are installed. Do not overtighten the fasteners connecting the ledger to the host structure.

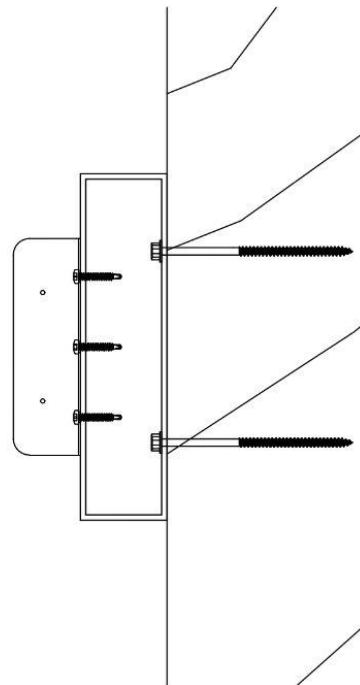
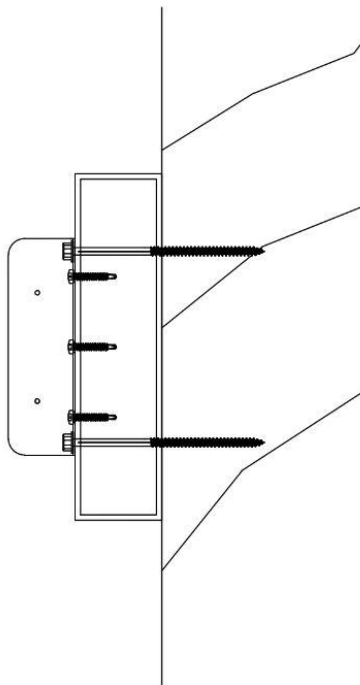
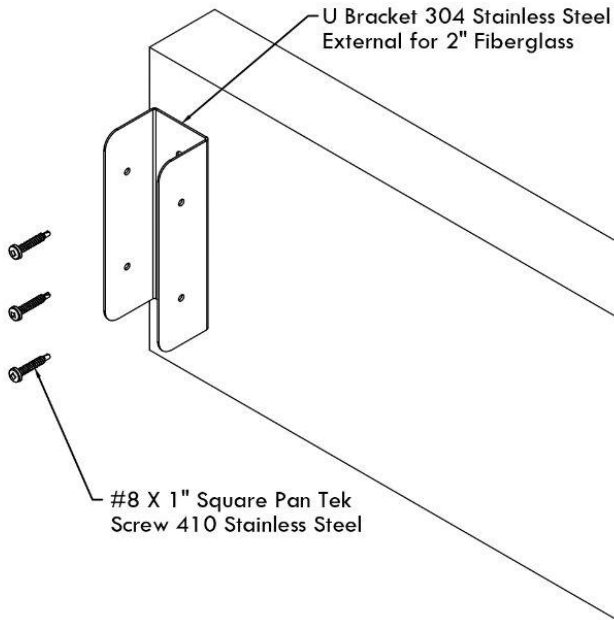

## Install Rafters

Position the center rafter onto both double beams for a freestanding structure or the ledger/internal bracket and the double beam for an attached structure. Ensure that the rafter is level for flat structures or has the correct amount of pitch for sloped structures. Check that the beam is the correct distance away from the ledger or other beam before securing the rafter. Repeat this process for the outermost rafters and then the remaining inside rafters. Check that rafters match the layout in the shop drawing.

If the structure includes fan or canopy blocks or integrations such as lighting or wiring, install brackets and blocking per the instructions, make connections, chase wires, and test the connections before final installation of the rafters.

When securing rafters to the internal brackets mounted to the ledger, it can be helpful to pre-drill the rafter and internal bracket.

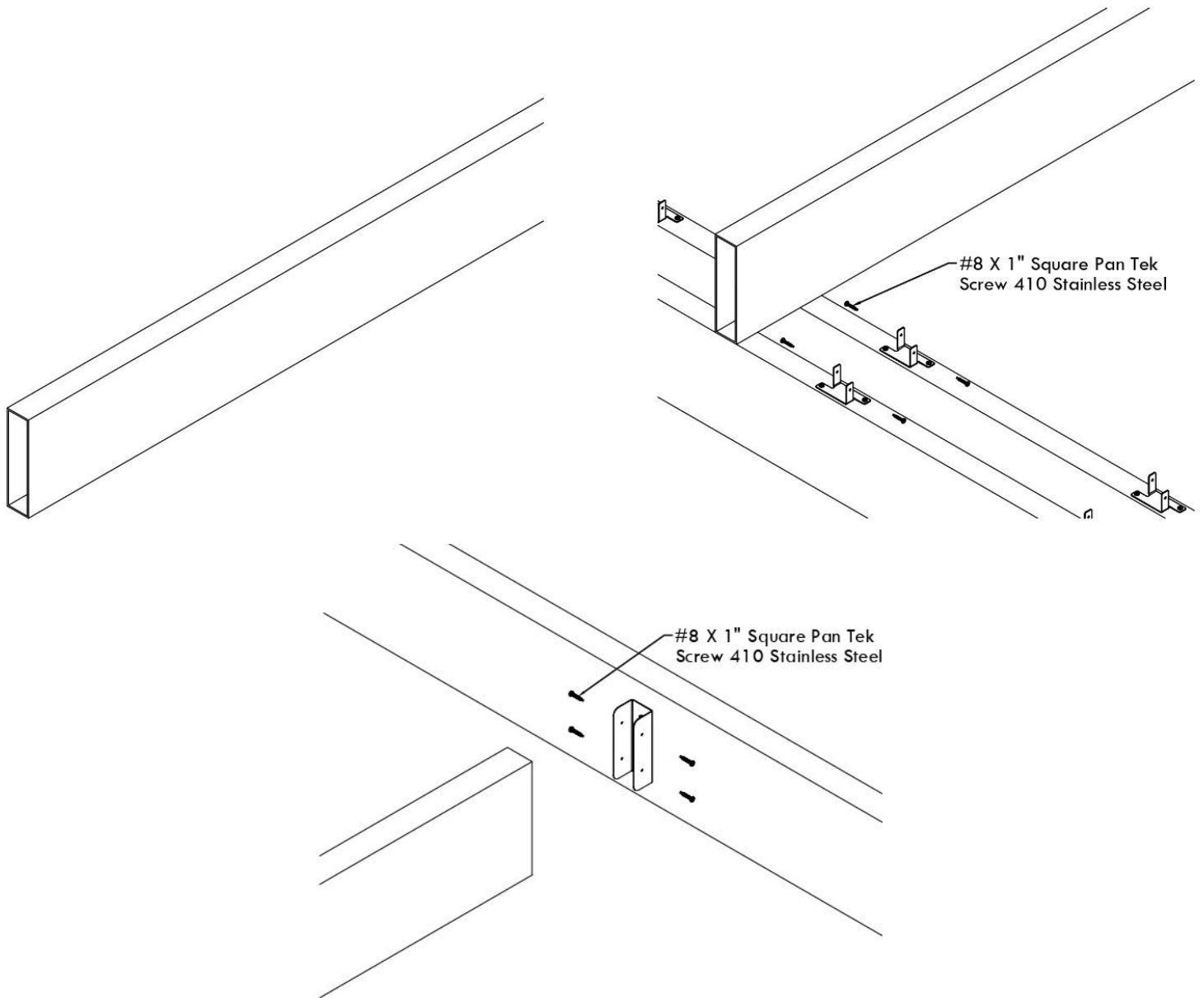

## Install Brackets and Fascias - Attached Structures

Install the internal brackets for the rafters and side fascias on the front fascia with screws. Install the side fascia, front fascia, and the remaining side fascia in sequence with screws. The front fascia must be installed at a slight angle so that the last side fascia can be installed. Once the front fascia can be fully inserted into the last side fascia, secure the front fascia with screws on all rafters.

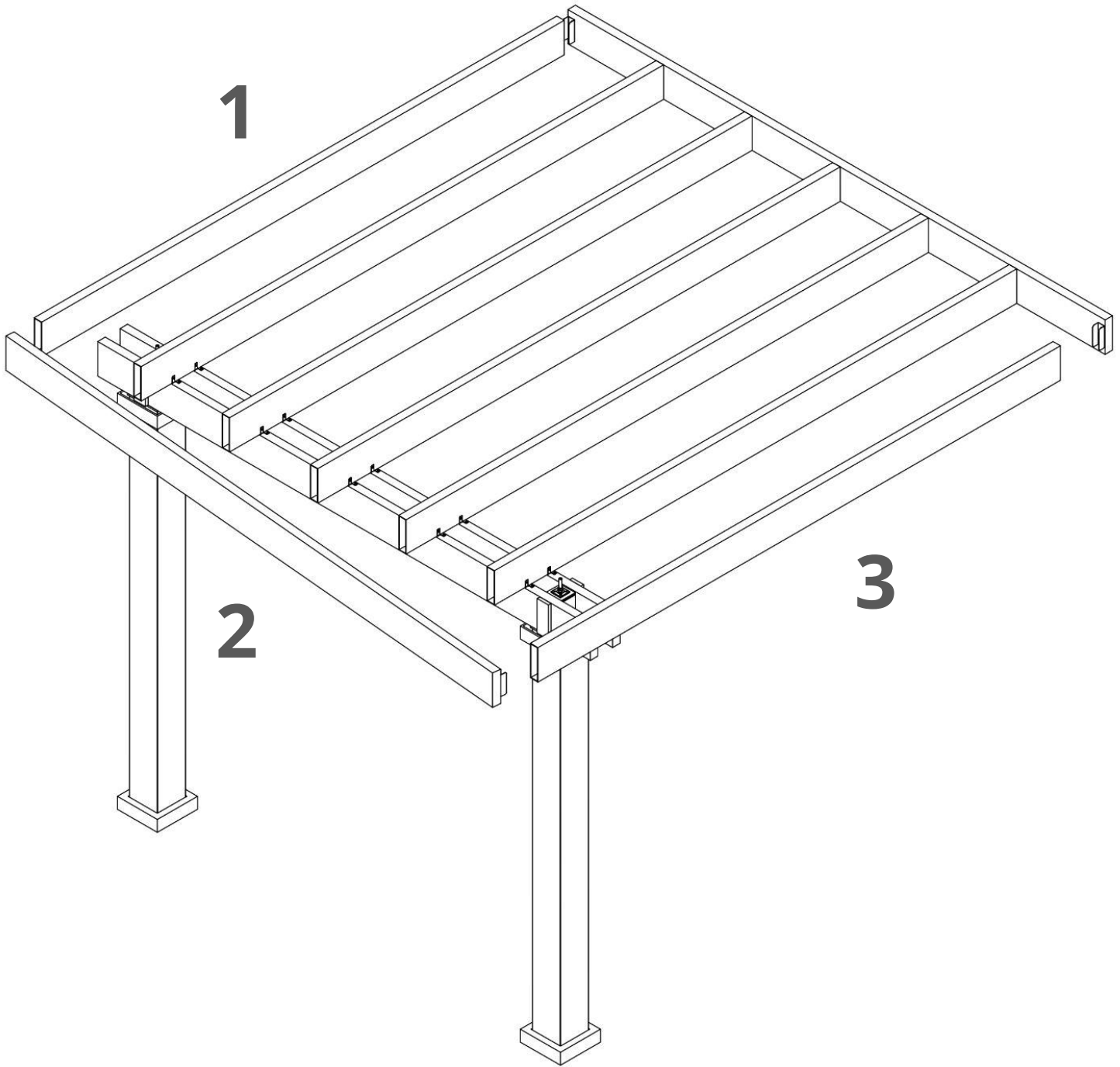

## Install Brackets and Fascias - Freestanding Structures

Install the internal brackets for the rafters and side fascias on the front and rear fascias with screws. Install the fascias in the sequence shown with screws. The front fascia must be installed at a slight angle so that the last side fascia can be installed. Once the front fascia can be fully inserted into the last side fascia, secure the front fascia with screws on all rafters.

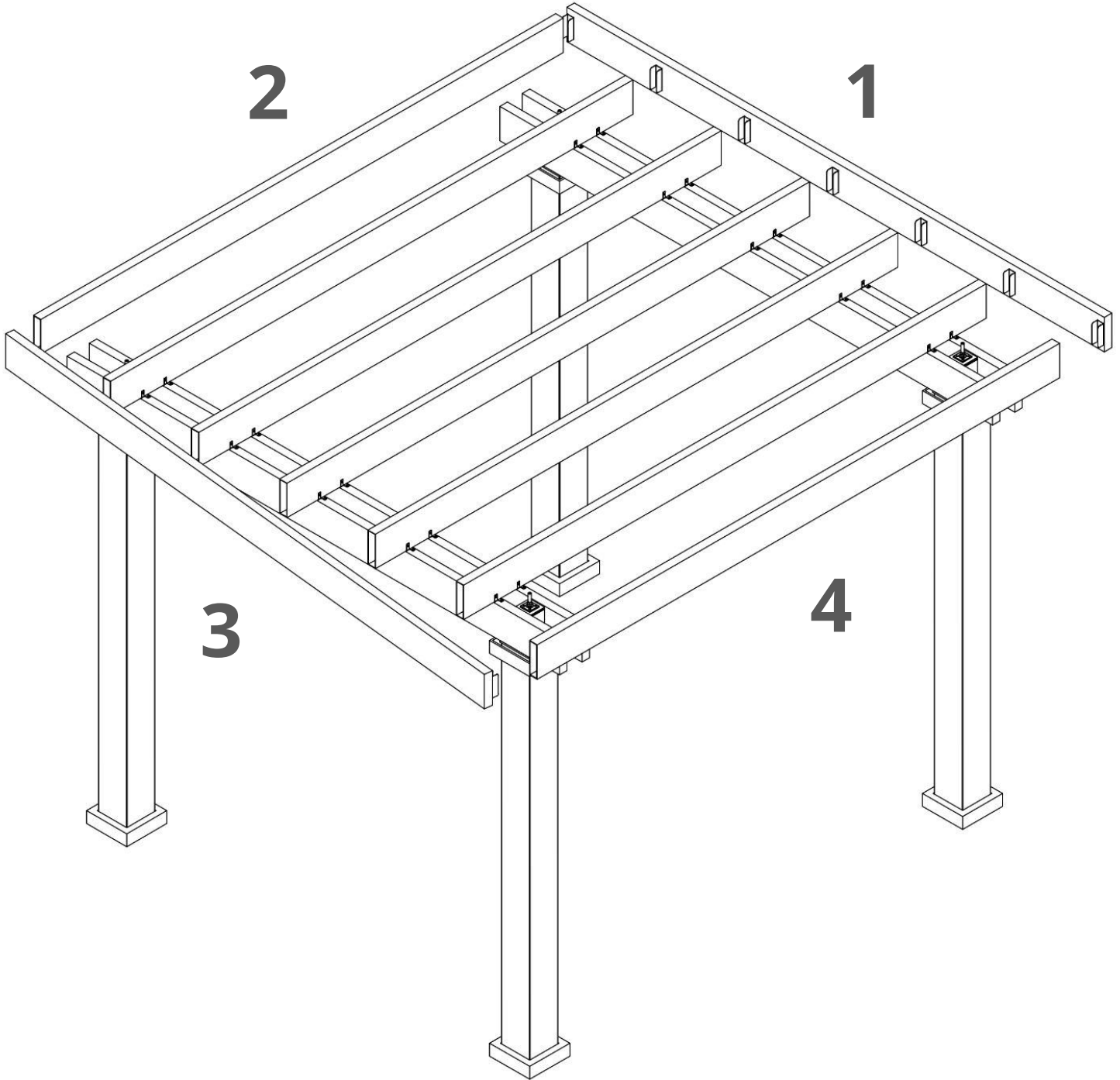

## Install Panels

Position the panels according to the layout in the shop drawing. Ensure that panels are oriented properly and that the correct side is facing up. Secure panels with screws with EPDM washers. Do not fully tighten the screws, the panels must be allowed to move slightly for expansion/contraction.

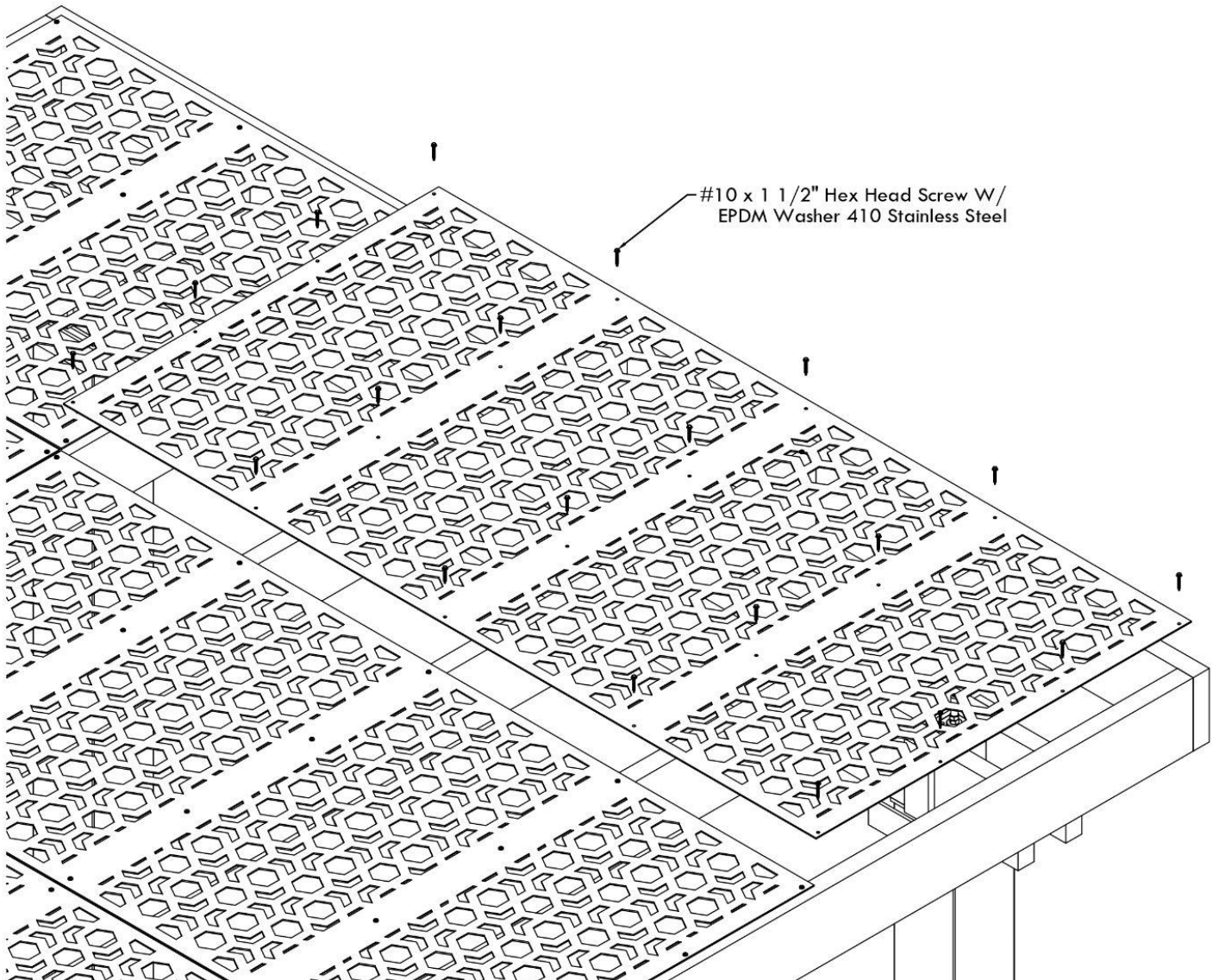



## Install Keystones

Keystones are provided to cover seams or hardware in beams and rafters. Secure the keystones with screws.

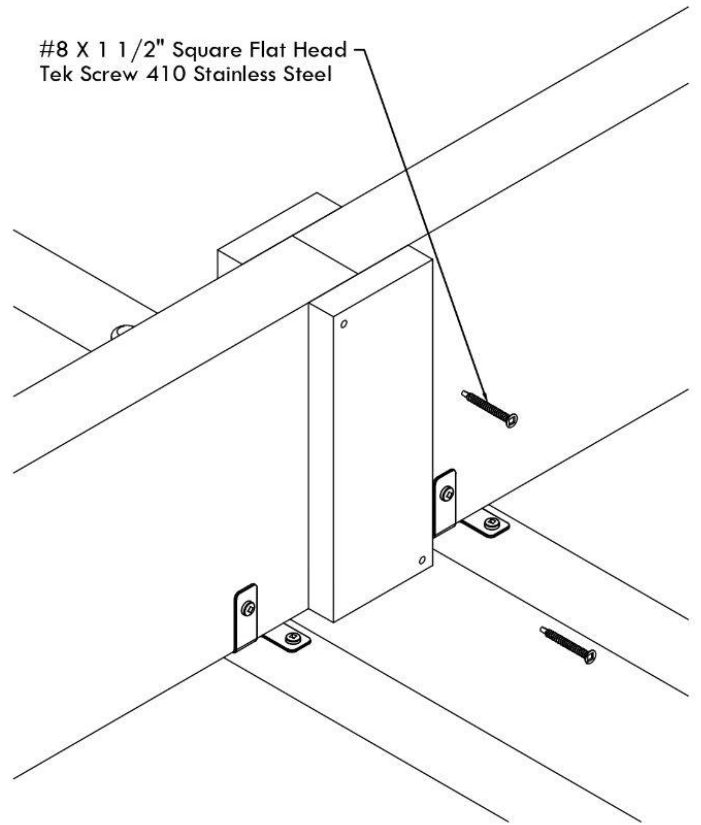
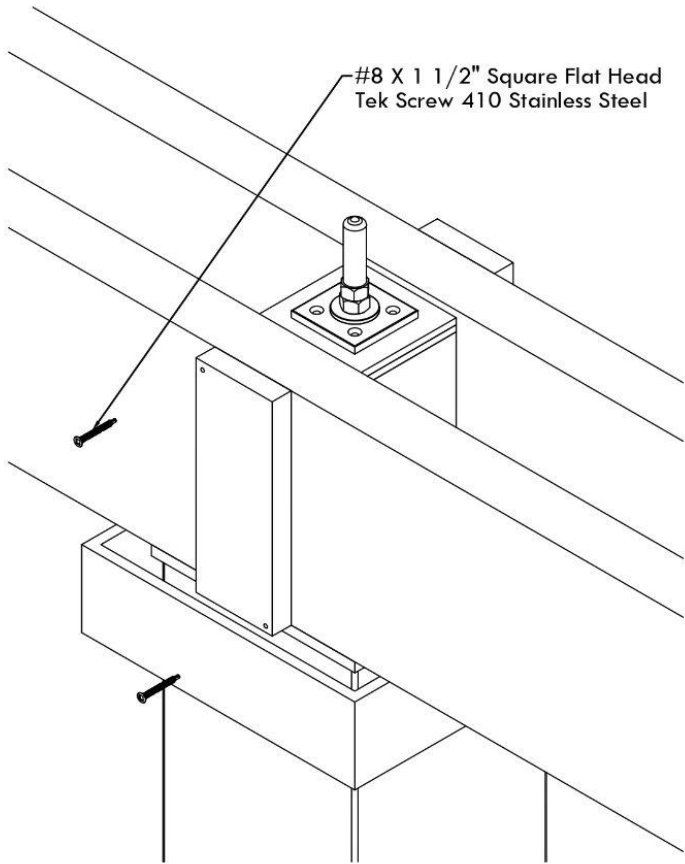

## Other Conditions

### Beam to Wall Connection

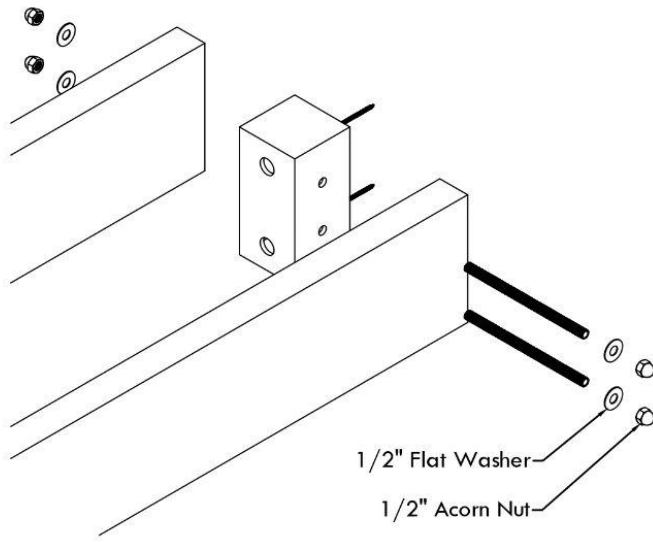

### Angled Beam Connection

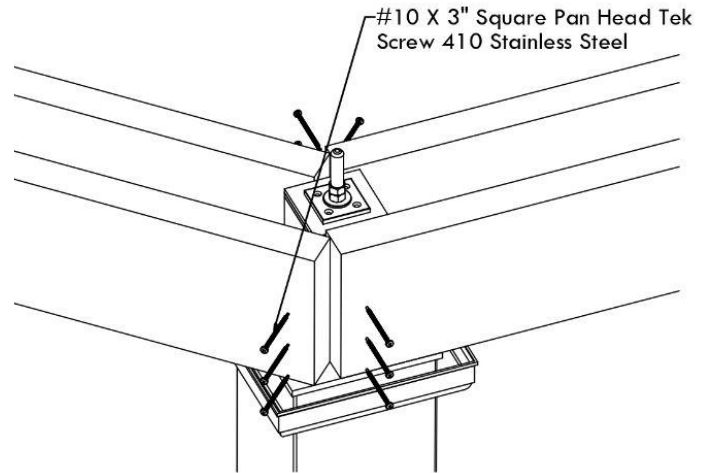

### Beam Blocking

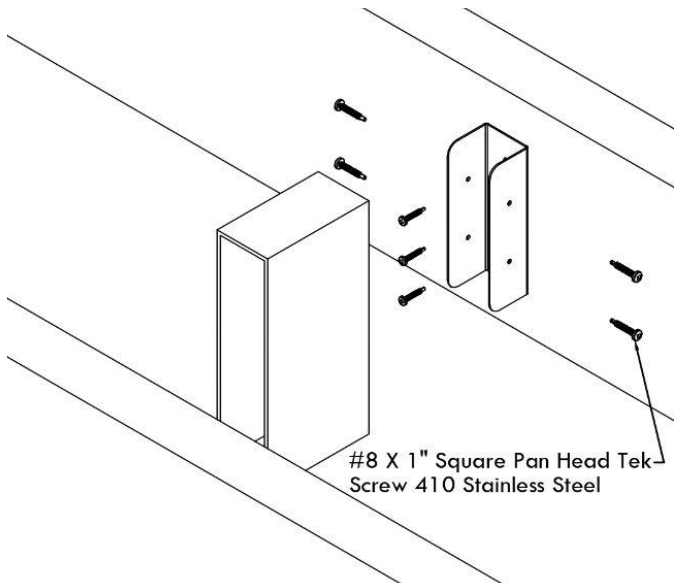

### Angled Rafter Connection

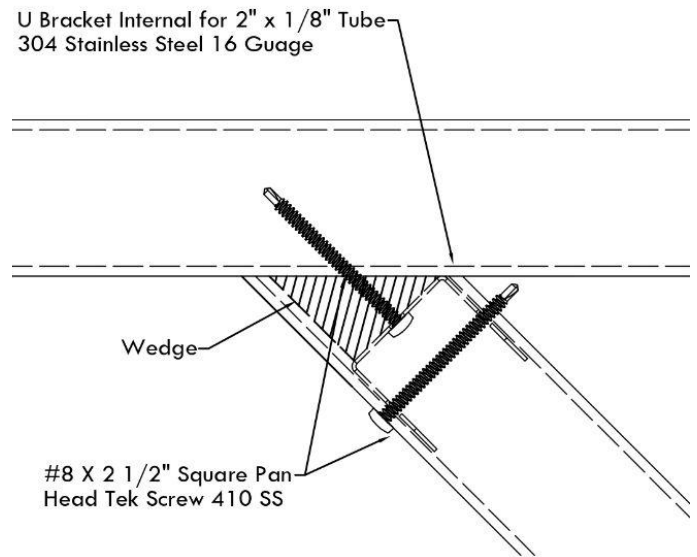

## Paint Touch-Up

All ColorLast finished structures will require touch up over time and at completion of construction. Use extreme care when handling painted components. Touch up paint is provided. In the event of scratching or cracking, touch up the painted surface with a foam or bristle brush. Apply light coats in order to allow the paint to dry with a smooth finish.

## Water Drainage

Weep holes must be drilled in the bottom of any hollow components so that water may drain. Failure to create proper drainage may result in finish or component failure and is not covered by the warranty.