

Fiberglass Column Installation Guide

Read this guide and review shop drawings and notes before beginning installation.

All packages should be opened and inspected for hidden damage upon receipt. Any missing or damaged components should be noted on the delivery receipt with the carrier before accepting the shipment. All items should be repackaged and stored where protected from moisture, dirt, and excessive heat. Do not wrap material so that heat or moisture can become trapped. Ensure that items are level, fully supported, and have airflow between parts. Damage from improper storage is not considered shipping damage and is not covered by product warranties. Handle materials so as to protect materials, coatings, fabric and finishes during transportation and installation to prevent damage or staining.

It is the responsibility of the installer to meet or exceed all code and safety requirements, and to obtain all required building permits. These instructions are only a guide, and may not address every circumstance. The installer should determine and implement appropriate installation techniques for each situation. Structureworks shall not be held liable for improper or unsafe installations.

Recommended Tools

The tools required for installation will vary depending on structure configuration and the hardware used. Review shop drawings to confirm drill bit sizes, socket sizes, and other project specific tools.

- Pencil
- 4' Level
- Torpedo Level
- 8' Ladder (2)
- Framing Square
- 5/8" x 8" Masonry Drill Bit
- Impact Driver with Phillips Bit
- Adjustable Wrench
- Tape Measure
- Socket Wrench with Deep Sockets
- Hacksaw/Bolt Cutters
- Drill
- Circular Saw with Fine Tooth Blade
- Compressed Air
- Hole-Cleaning Brush
- Caulk Gun

Required Materials

Depending on the configuration of the structure, additional materials such as anchoring epoxy may be needed. Review shop drawings for project specific requirements.

Cleaning and Maintenance

Use a combination of Simple Green All-Purpose Cleaner and hot water with a soft bristle brush. Clean after installation and on an annual basis. For more difficult to clean marks, a Mr. Clean Magic Eraser can be used. Structural attachments should be inspected annually.

Layout

Layout all columns according to the shop drawings. Columns must be located precisely and variations in the height of the mounting surface must be accounted for by trimming or leveling each column. The structure will not install correctly if the columns are installed out of square or out of level from one another.

TensionRod Column Installation - Concrete Embedment

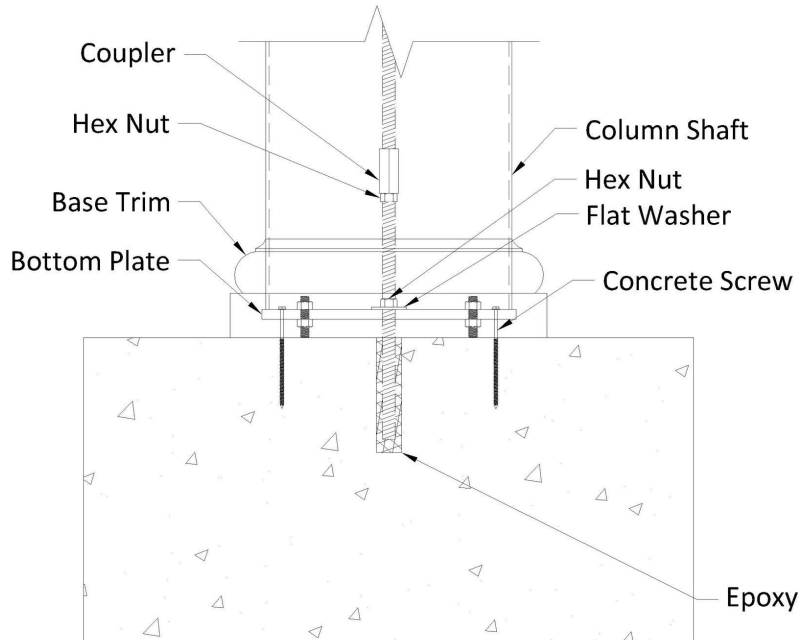

1. Trim Column Shaft, if Needed

If the shaft is not square at the top or bottom or if the height of the shaft must be adjusted, measure the desired length from the top of the shaft and mark several locations around the shaft. Next, apply painter's tape around the shaft so that the edge of the tape aligns with the marks. Using a circular saw, cut along the tape line. Cut with the motor side of the saw on the cut-off portion to prevent damaging the finish.

2. Drill Threaded Rod Hole

Drill the hole for the threaded rod and epoxy. The hole should be sized larger than the threaded rod diameter per the epoxy manufacturer's instructions. Clean the hole.

3. Install Epoxy and Threaded Rod

Fill the hole with epoxy per the manufacturer's instructions. Insert the short threaded rod in a twisting motion to ensure epoxy flows into the threads of the rod. Ensure that the rod is inserted to the proper depth and is plumb.

4. Install Column Bottom Plate

Install the leveling bolts on the column bottom plate and slide it over the installed threaded rod. Level the plate by adjusting the leveling bolts to accommodate any slope or irregularity in the mounting surface. Once the column bottom plate has been leveled, install a flat washer and a hex nut on the threaded rod and tighten. Next, drill four holes for the hex head concrete anchors and install. Finally, install a hex nut and coupler onto the threaded rod. Tighten the hex nut and coupler against each other to prevent the coupler from coming loose. The coupler should be installed so that half of the threads are open to receive the next threaded rod.

5. Install Base Trim and Column Shaft

Place the base trim around the assembly on the ground. Then, lift the shaft over the short threaded rod and set it on the column bottom plate and into the base trim. Next, install the remaining length(s) of threaded rod from above using a ladder. Ensure that the threaded rod properly engages the coupler and is fully tightened.

6. Position Capital and Mid-Trim

Slide the mid-trim (if provided) and the capital onto the shaft. These components will be secured once the structure has been fully installed.

7. Install Top Plate

Slide the top plate over the threaded rod.

- For use with a single beam; slide the beam over the threaded rod and rest the beam on the top plate. Next, install a 1/4" x 2 1/2" x 2 1/2" washer, flat washer, and two hex nuts. Tighten to 30 ft. lbs.
- For use with double beams; slide the double beam adapter block over the threaded rod. Next, install a 1/4" x 2 1/2" x 2 1/2" washer, flat washer, and two hex nuts. Tighten to 30 ft. lbs.

8. Trim Threaded Rod, if Needed

Trim the threaded rod with a hacksaw or bolt cutters if it is more than 2" above the top hex nut. Clean up any shavings from the threaded rod around the structure and in the column capital, as they can cause rust to form. Install the threaded rod cap on top of the threaded rod.

9. Install Capital and Mid-Trim

Once the structure is fully installed, slide the mid-trim and capital into position. Secure the capital using two 2" pan head tek screws. Caulk the mid-trim with an exterior latex caulk to secure.

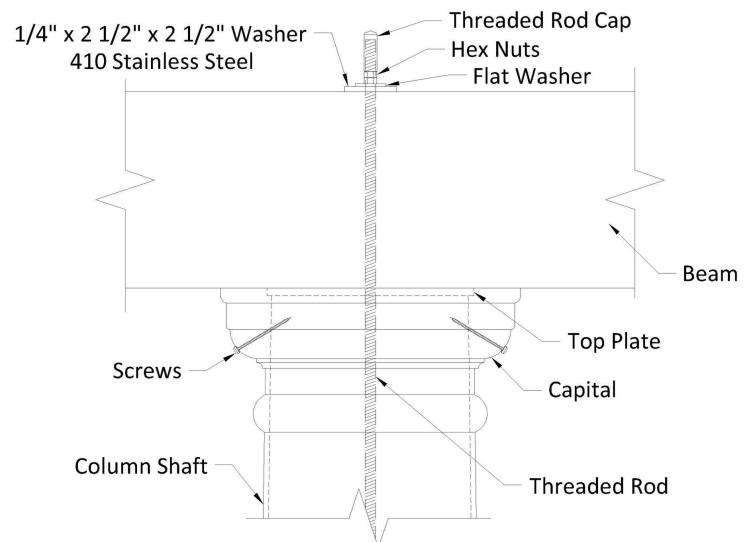
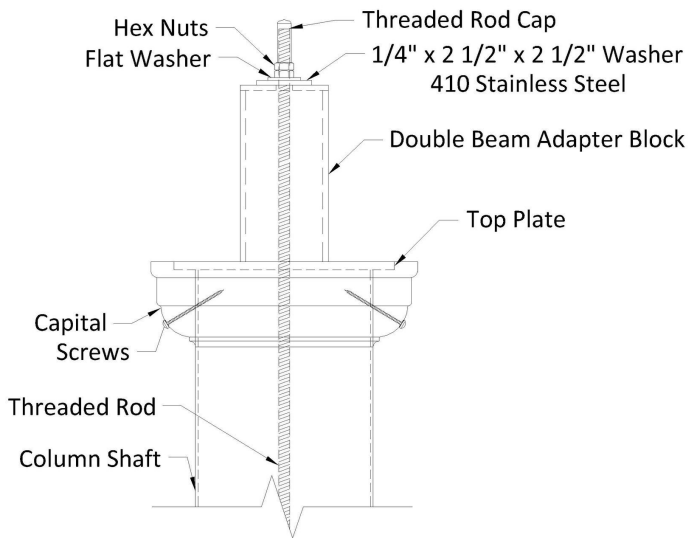

TensionRod Column Installation - Framing Mount

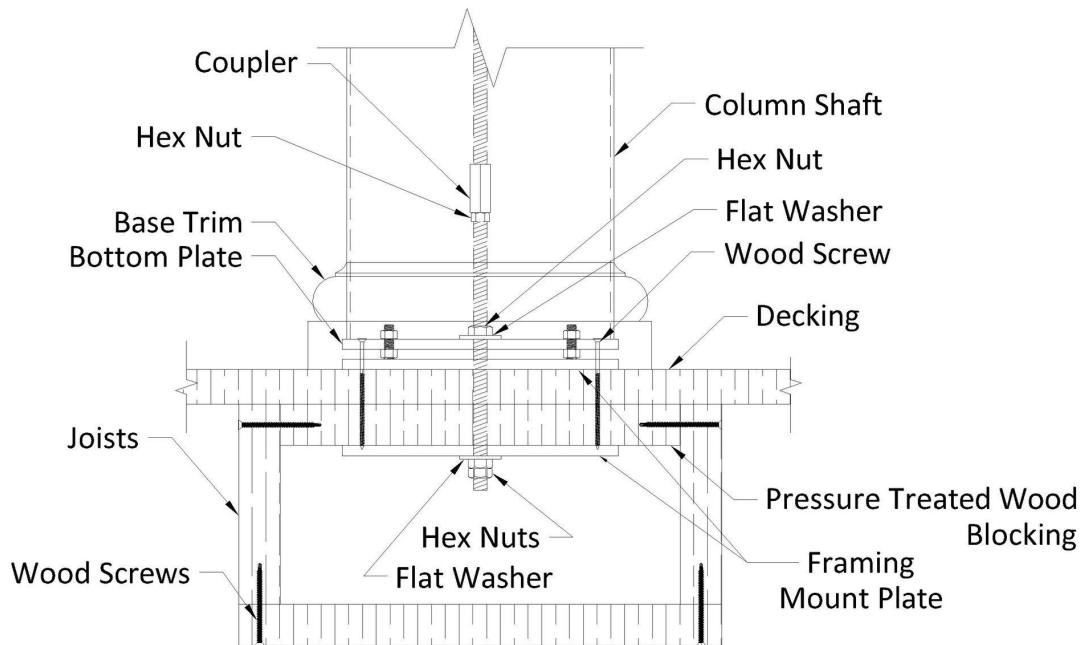

1. Trim Column Shaft, if Needed

If the shaft is not square at the top or bottom or if the height of the shaft must be adjusted; measure the desired length from the top of the shaft and mark several locations around the shaft. Next, apply painter's tape around the shaft so that the edge of the tape aligns with the marks. Using a circular saw, cut along the tape line. Cut with the motor side of the saw on the cut-off portion to prevent damaging the finish.

2. Install Blocking

Install pressure treated wood blocking between the joists, against the underside of the decking. Blocking should be a nominal thickness of 2" and wider than the framing mount plate.

3. Drill Threaded Rod Hole

Drill the hole for the threaded rod through the deck and wood blocking.

4. Install Framing Mount Plates and Threaded Rod

Install a short length of threaded rod with a flat washer and hex nut up through the framing mount plate and through the hole in the blocking and decking. Place a second framing mount plate over the threaded rod and onto the deck surface.

5. Install Column Bottom Plate

Install the leveling bolts on the column bottom plate and slide it over the installed threaded rod. Level the plate by adjusting the leveling bolts to accommodate any slope or irregularity in the mounting surface. Once the column bottom plate has been leveled, install a flat washer and a hex nut on the threaded rod and tighten. Next, drill four holes through the framing mount plate on the deck surface. Install four wood screws through the bottom plate, framing mount plate, and into the deck and blocking. Finally, install a hex nut and coupler onto the threaded rod. Tighten the hex nut and coupler against each other to prevent the coupler from loosening. The coupler should be installed so that half of the threads are open to receive the next threaded rod.

6. Install Base Trim and Column Shaft

Place the base trim around the assembly on the deck. Then, lift the shaft over the short threaded rod and set it on the column bottom plate and into the base trim. Next, install the remaining length(s) of threaded rod from above using a ladder. Ensure that the threaded rod properly engages the coupler and is fully tightened.

7. Position Capital and Mid-Trim

Slide the mid-trim (if provided) and the capital onto the shaft. These components will be secured once the structure has been fully installed.

8. Install Top Plate

Slide the top plate over the threaded rod.

- For use with a single beam; slide the beam over the threaded rod and rest the beam on the top plate. Next, install a 1/4" x 2 1/2" x 2 1/2" washer, flat washer, and two hex nuts. Tighten to 30 ft. lbs.
- For use with double beams; slide the double beam adapter block over the threaded rod. Next, install a 1/4" x 2 1/2" x 2 1/2" washer, flat washer, and two hex nuts. Tighten to 30 ft. lbs.

9. Trim Threaded Rod, if Needed

Trim the threaded rod with a hacksaw or bolt cutters if it is more than 2" above the top hex nut. Clean up any shavings from the threaded rod around the structure and in the column capital, as they can cause rust to form. Install the threaded rod cap on top of the threaded rod.

10. Install Capital and Mid-Trim

Once the structure is fully installed, slide the mid-trim and capital into position. Secure the capital using two 2" pan head tek screws. Caulk the mid-trim with an exterior latex caulk to secure.

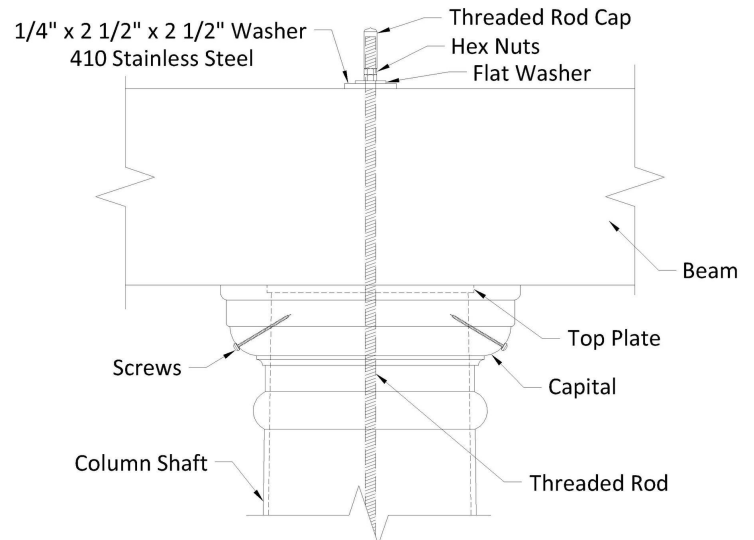
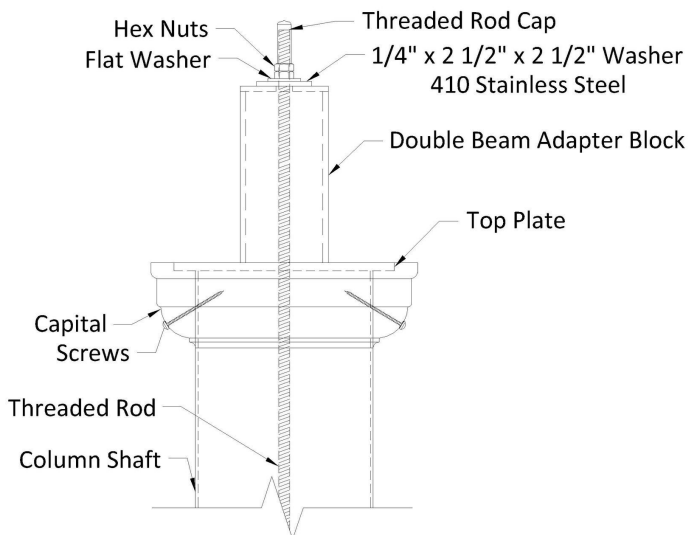

Aluminum Reinforced Fiberglass Column Installation - Concrete Embedment

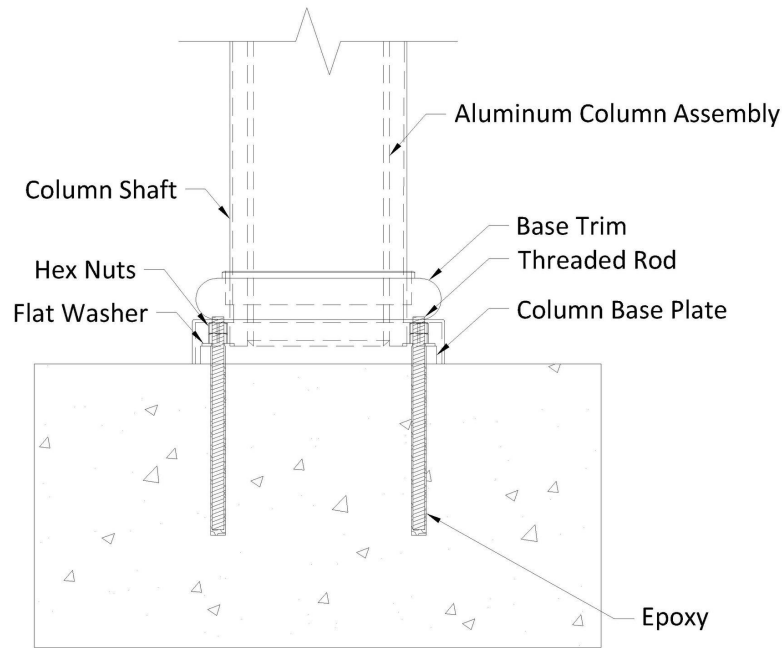

1. Drill Threaded Rod Holes

Drill the holes for the threaded rods and epoxy. The holes should be sized larger than the threaded rod diameter per the epoxy manufacturer's instructions. Clean the hole.

2. Install Epoxy and Threaded Rods

Fill the holes with epoxy per the manufacturer's instructions. Insert the threaded rods in a twisting motion to ensure epoxy flows into the threads of the rods. Ensure that the rods are inserted to the proper depth and are plumb.

3. Position Fiberglass Shaft

Tip the aluminum column assembly onto its side and slide the fiberglass shaft over it. This is safer and easier than lifting the fiberglass shaft up and over the aluminum column assembly while it is upright. Once upright, the fiberglass shaft can be lifted several inches and placed on temporary blocks to allow for access to the column base plate and mounting hardware, if required.

4. Install Aluminum Column

If the mounting surface is uneven, flat washers and non-shrink grout can be used to shim and level the surface. Once the column base plate has been leveled, install flat washers and hex nuts on the threaded rods and tighten.

5. Install Base Trim

Place the base trim over the top of the column assembly and lower it to the ground. Some columns will have more than one base trim.

6. Position Capital and Mid-Trim

Slide the mid-trim (if provided) and the capital onto the shaft. These components will be secured once the structure has been fully installed.

7. Install Threaded Rod

Install threaded rod into the top of the aluminum column assembly.

- For use with a single beam; slide the beam over the threaded rod and rest the beam on the top of the aluminum column assembly. Next, install a 1/4" x 2 1/2" x 2 1/2" washer, flat washer, and two hex nuts. Tighten to 30 ft. lbs.
- For use with double beams; slide the double beam adapter block over the threaded rod. Next, install a 1/4" x 2 1/2" x 2 1/2" washer, flat washer, and two hex nuts. Tighten to 30 ft. lbs.

8. Trim Threaded Rod, if Needed

Trim the threaded rod with a hacksaw or bolt cutters if it is more than 2" above the top hex nut. Clean up any shavings from the threaded rod around the structure and in the column capital, as they can cause rust to form. Install the threaded rod cap on top of the threaded rod.

9. Install Capital and Mid-Trim

Once the structure is fully installed, slide the mid-trim and capital into position. Secure the capital using two 2" pan head tek screws. Caulk the mid-trim with an exterior latex caulk to secure.

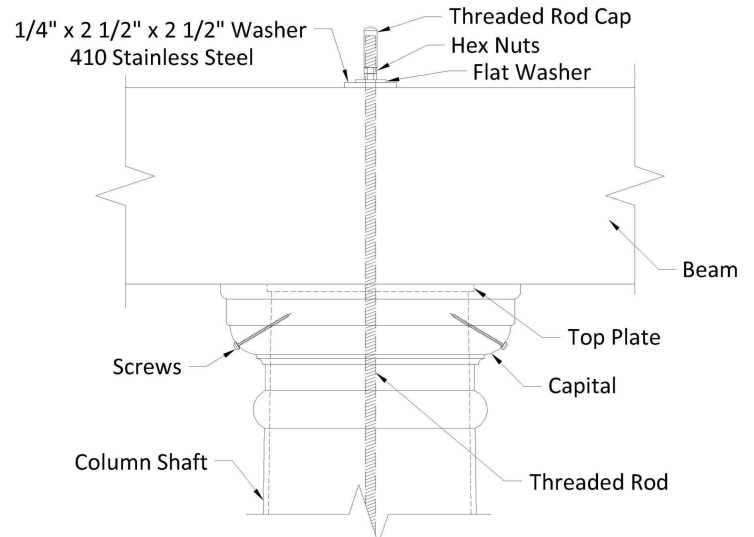
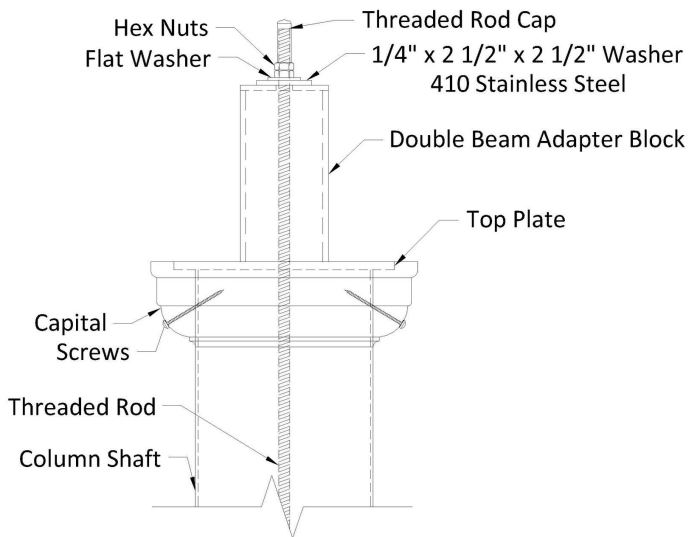

Aluminum Reinforced Fiberglass Column Installation - Through Bolt

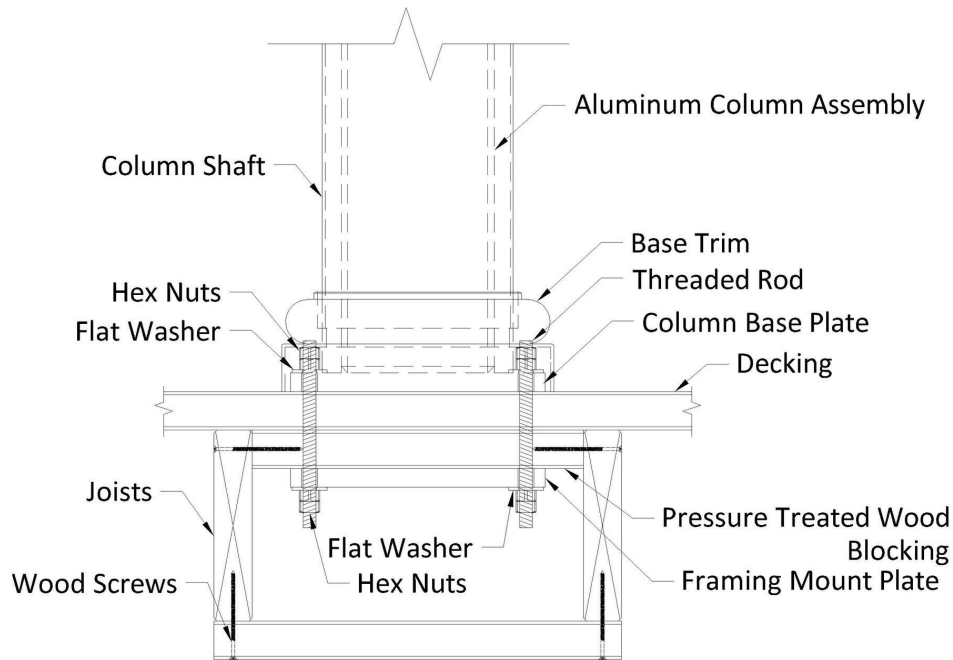

1. Install Blocking

Install pressure treated wood blocking between the joists against the underside of the decking. Blocking should be a nominal thickness of 2" and wider than the framing mount plate.

2. Drill Threaded Rod Hole

Drill the holes for the threaded rods through the deck and wood blocking.

3. Position Fiberglass Shaft

Tip the aluminum column assembly onto its side and slide the fiberglass shaft over it. This is safer and easier than lifting the fiberglass shaft up and over the aluminum column assembly while it is upright. Once upright, the fiberglass shaft can be lifted several inches and placed on temporary blocks to allow for access to the column base plate and mounting hardware, if required.

4. Install Aluminum Column

If the mounting surface is uneven, flat washers can be used to shim and level the base plate. Once the column base plate has been leveled, install flat washers and hex nuts on the threaded rods and tighten.

5. Install Base Trim

Place the base trim over the top of the column assembly and lower it to the ground. Some columns will have more than one base trim.

6. Position Capital and Mid-Trim

Slide the mid-trim (if provided) and the capital onto the shaft. These components will be secured once the structure has been fully installed.

7. Install Threaded Rod

Install threaded rod into the top of the aluminum column assembly.

- For use with a single beam; slide the beam over the threaded rod and rest the beam on the top of the aluminum column assembly. Next, install a 1/4" x 2 1/2" x 2 1/2" washer, flat washer, and two hex nuts. Tighten to 30 ft. lbs.
- For use with double beams; slide the double beam adapter block over the threaded rod. Next, install a 1/4" x 2 1/2" x 2 1/2" washer, flat washer, and two hex nuts. Tighten to 30 ft. lbs.

8. Trim Threaded Rod, if Needed

Trim the threaded rod with a hacksaw or bolt cutters if it is more than 2" above the top hex nut. Clean up any shavings from the threaded rod around the structure and in the column capital, as they can cause rust to form. Install the threaded rod cap on top of the threaded rod.

9. Install Capital and Mid-Trim

Once the structure is fully installed, slide the mid-trim and capital into position. Secure the capital using two 2" pan head tek screws. Caulk the mid-trim with an exterior latex caulk to secure.

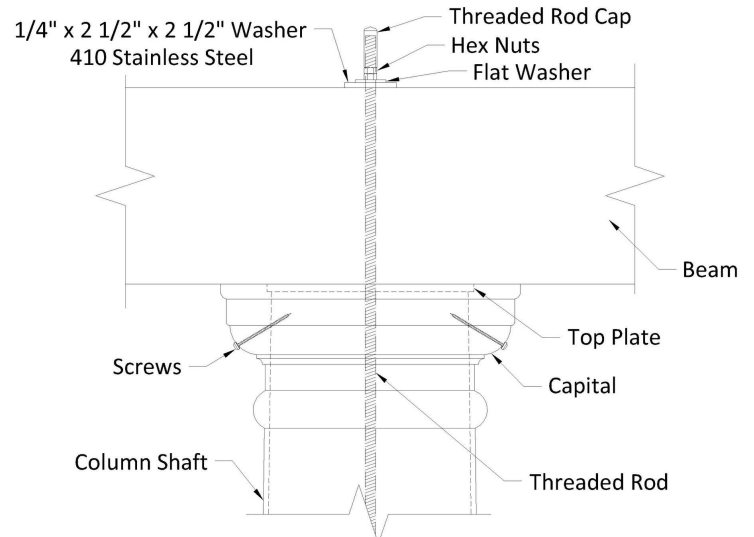
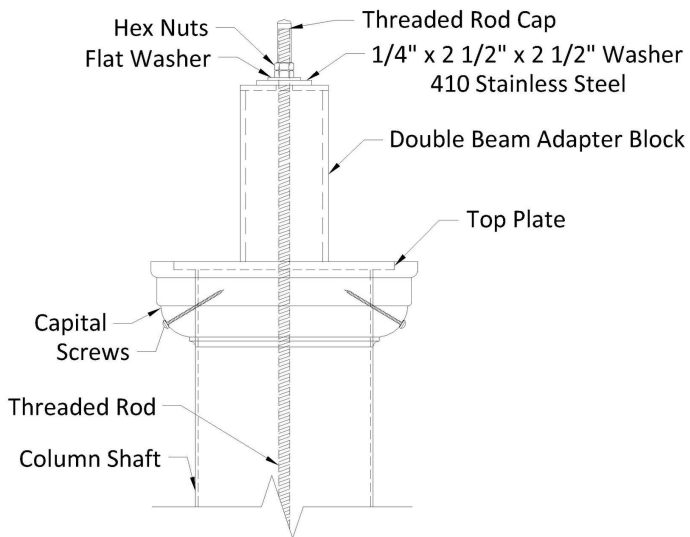

Paint Touch-Up

All ColorLast finished components will require touch up over time and at completion of construction. Use extreme care when handling painted components. Touch up paint is provided. In the event of scratching or cracking, touch up the painted surface with a foam or bristle brush. Apply light coats to allow the paint to dry with a smooth finish.