

Umbra PSC Installation Guide

Read this guide and review shop drawings and notes before beginning installation.

All packages should be opened and inspected for hidden damage upon receipt. Any missing or damaged components should be noted on the delivery receipt with the carrier before accepting the shipment. All items should be repackaged and stored where protected from moisture, dirt, and excessive heat. Do not wrap material so that heat or moisture can become trapped. Ensure that items are level, fully supported, and have airflow between parts. Damage from improper storage is not considered shipping damage and is not covered by product warranties. Handle materials so as to protect materials, coatings, fabric and finishes during transportation and installation to prevent damage or staining.

It is the responsibility of the installer to meet or exceed all code and safety requirements, and to obtain all required building permits. These instructions are only a guide, and may not address every circumstance. The installer should determine and implement appropriate installation techniques for each situation. Structureworks shall not be held liable for improper or unsafe installations.

Recommended Tools

The tools required for installation will vary depending on canopy configuration and the hardware used. Review shop drawings to confirm drill bit sizes, socket sizes, and other project specific tools.

- Pencil
- 4' Level
- Ladder (2)
- Framing Square
- Needle Nose Pliers
- Adjustable Wrench
- Drill
- Caulk Gun
- Hole-Cleaning Brush
- Tape Measure
- Socket Wrench w/ Sockets
- Compressed Air

Required Materials

Depending on the configuration of the canopy, additional materials such as attachment hardware, silicone caulk, and anchoring epoxy may be needed. Review shop drawings for project specific requirements.

Cleaning and Maintenance

Use a combination of Simple Green All-Purpose Cleaner and hot water with a soft bristle brush. Clean after installation and on an annual basis. For more difficult to clean marks, a Mr. Clean Magic Eraser can be used. Structural attachments should be inspected annually.

Installation Sequence

This installation guide provides a step by step sequence for the installation of the canopy. This guide covers only the canopy, separate installation guides are provided for accessories and other products used in the installation of the canopy. Ensure that you have all required installation guides before beginning the installation.

All canopies are made to order and are provided with shop drawings. Shop drawings may contain additional information, details, or job specific instructions. Shop drawings take precedence over this installation guide.

Layout

Layout all mounting locations according to the shop drawings. The canopy will not install correctly if the mounting plates or frame are not installed in the proper location.

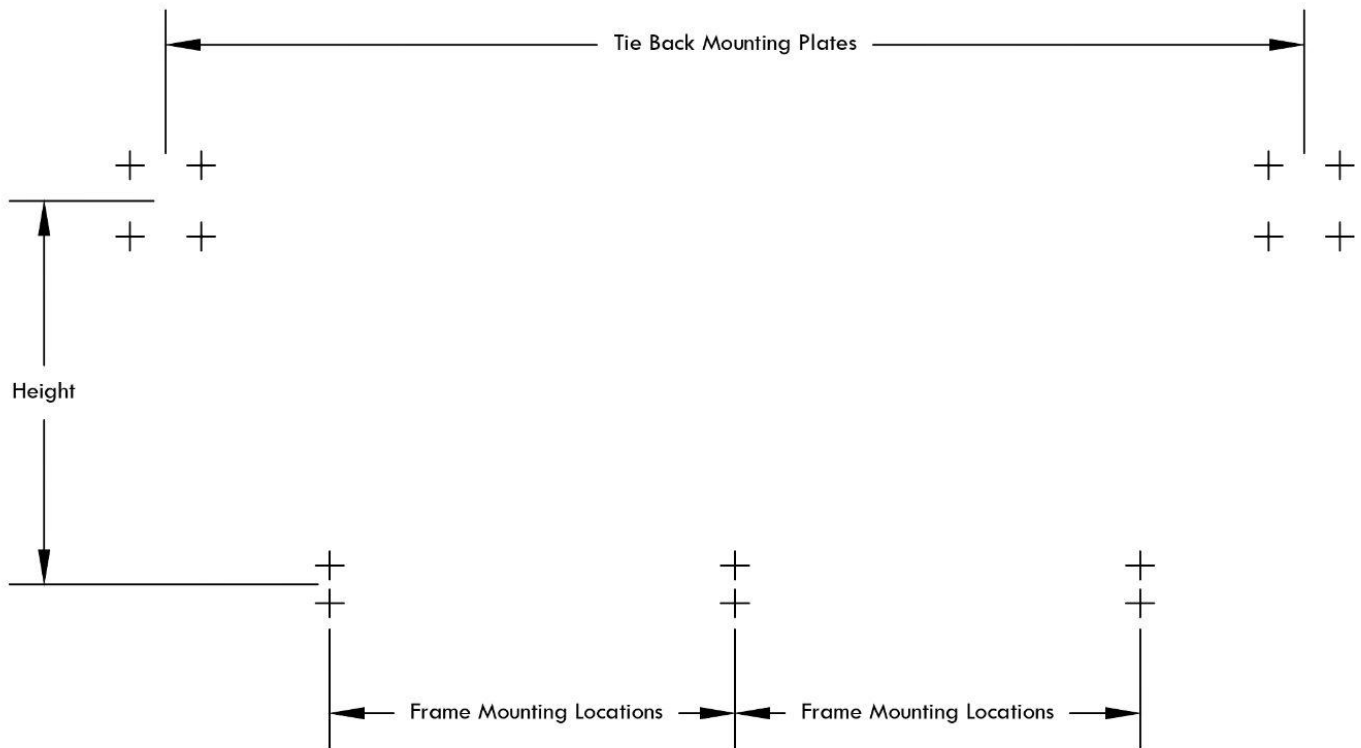

Canopy Attachment

For through bolt installations, drill holes for the threaded rods to pass through the wall. Install blocking as needed for wood or metal frame installations where the bolts do not pass through a structural member.

For concrete or masonry embedment installations, drill holes for the installation of threaded rods and epoxy. The holes should be sized larger than the threaded rod diameter per the epoxy manufacturer's instructions. Clean the hole thoroughly. Fill the holes with epoxy per the manufacturer's instructions. Insert the threaded rods in a twisting motion to ensure epoxy flows into the threads of the rods. Ensure that the rods are inserted to the proper depth and are aligned.

For installation to solid wood, install lag screws through the mounting holes.

Ensure that all attachment points are mounted to structural components that can support the loads of the canopy.

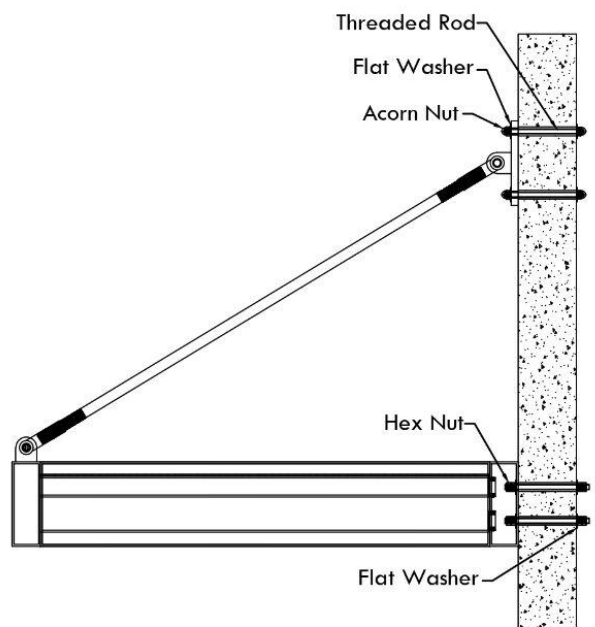
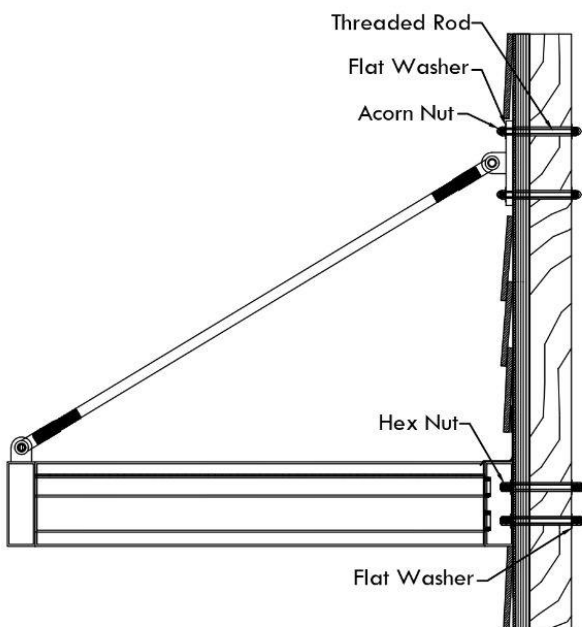
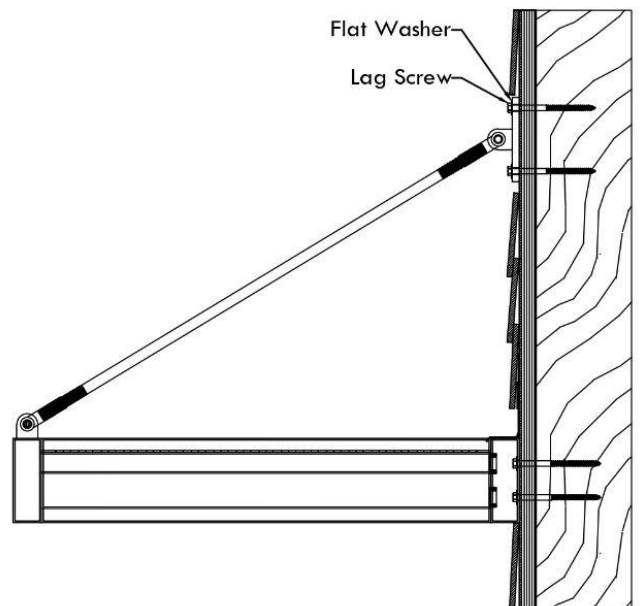
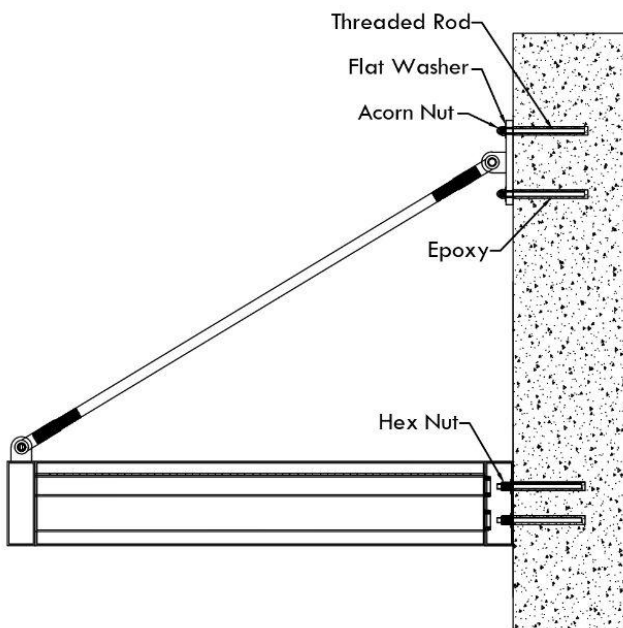

Install Tie Back Mounting Plates

Install the tie back mounting plates to the host structure. Hardware for tie back mounting plate attachment will vary depending on mounting conditions.

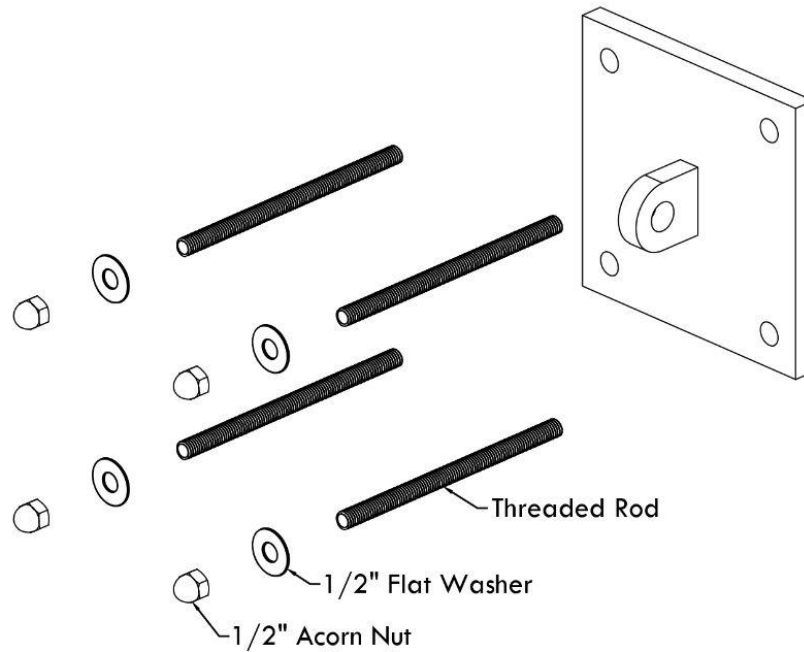

Install Tie Backs

Install the tie backs by placing the clevis fork around the mounting plate tab, next place the clevis pin through the clevis fork and mounting plate tab. Insert two cotter pins to retain the clevis pin. Bend the cotter pin legs so that the cotter pins are permanently secured.

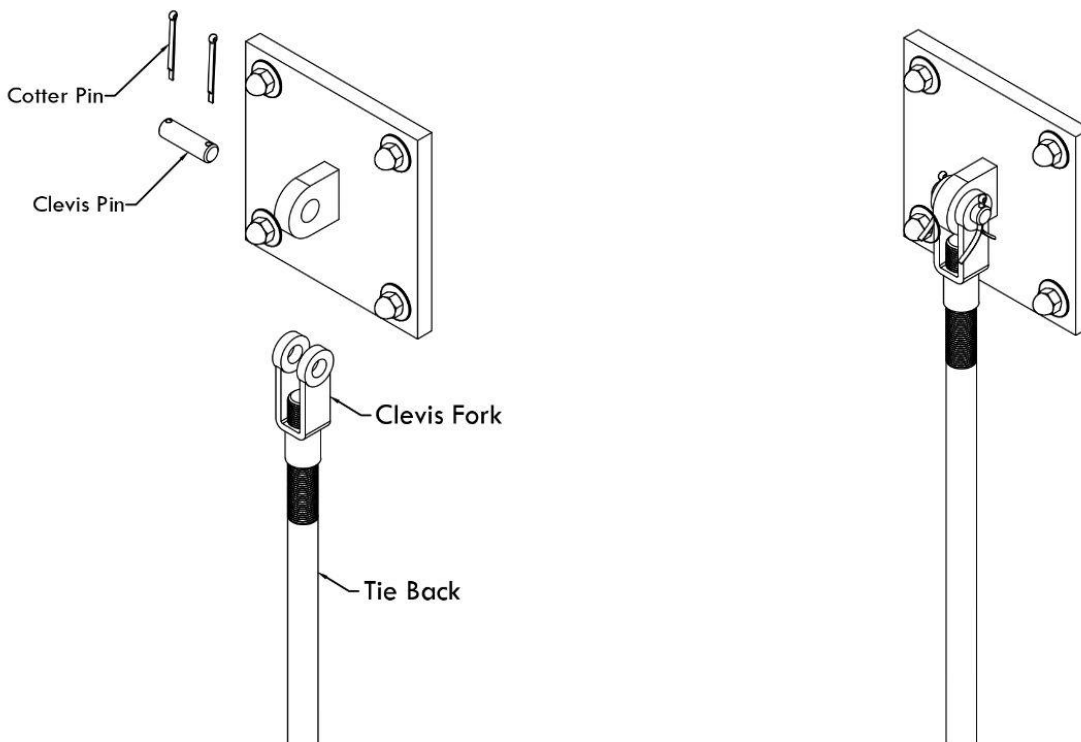

Install Canopy Frame

Lift the canopy frame into position and secure it to the tie backs using the clevis pin and cotter pins.

Position the attached portion of the canopy frame so that it is in alignment with the previously installed hardware, pre-drilled holes, or marks for lags screws. Secure the frame.

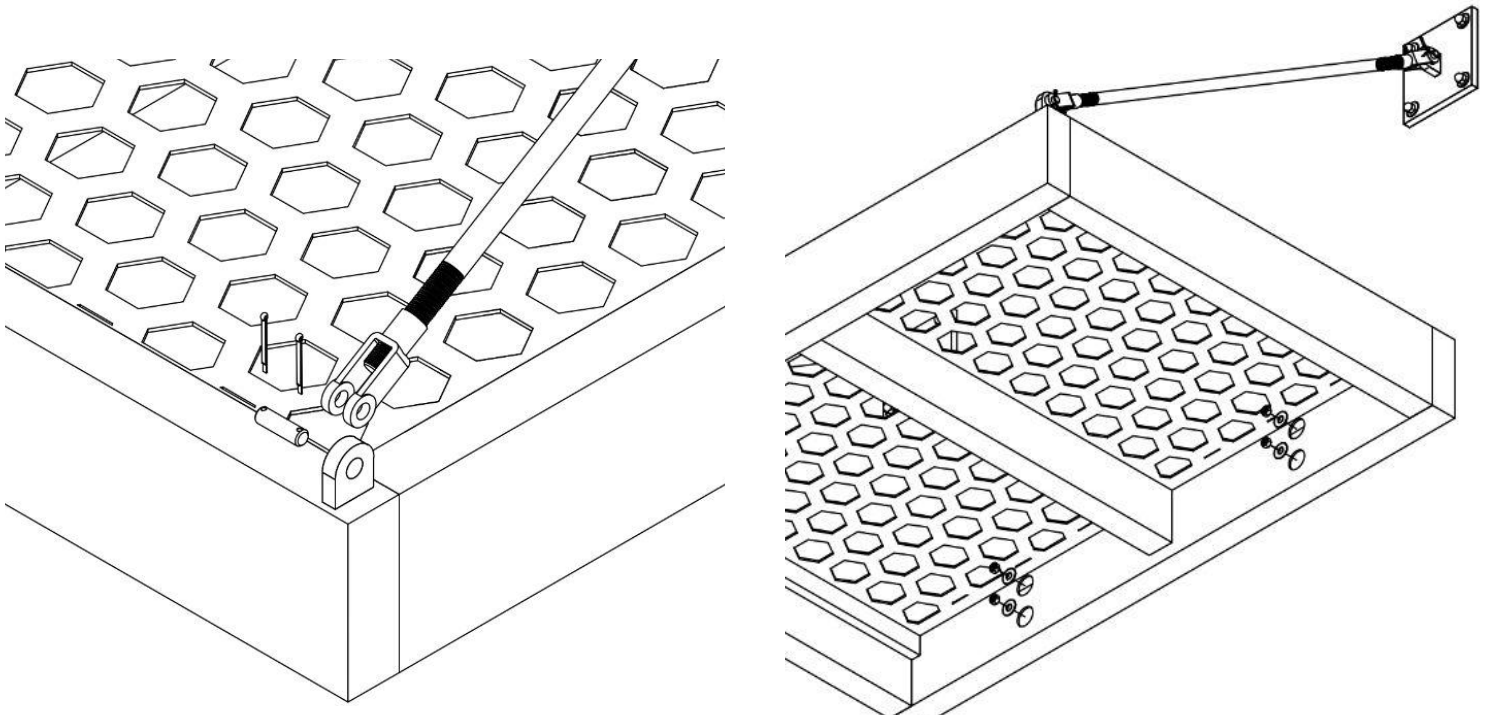

Install Hole Plugs

Install hole plugs into the face of the canopy frame.

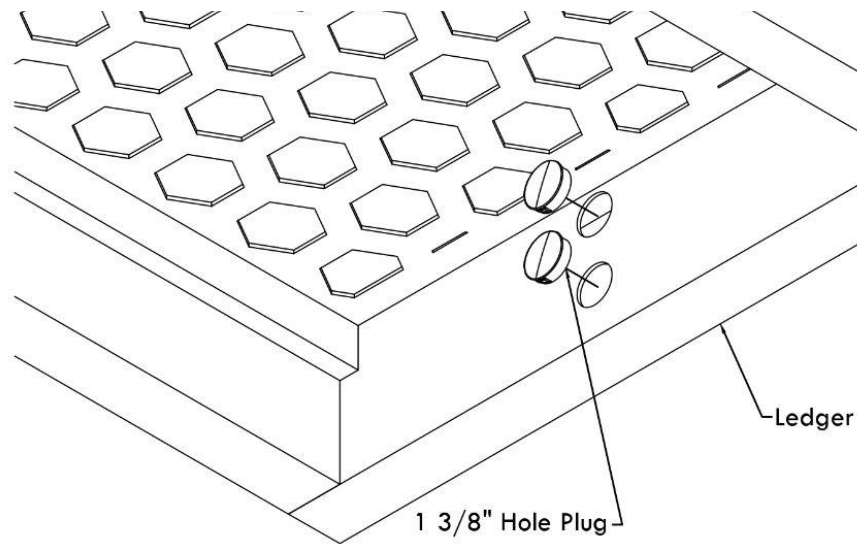

Paint Touch-Up

All canopies will require touch up over time and at completion of construction. Use extreme care when handling components. Touch up paint is provided. In the event of scratching or chipping, touch up the painted surface with the included brush. Apply light coats in order to allow the paint to flow and dry with a smooth finish.