

## Element Installation Guide

Read this guide and review shop drawings and notes before beginning installation.

All packages should be opened and inspected for hidden damage upon receipt. Any missing or damaged components should be noted on the delivery receipt with the carrier before accepting the shipment. All items should be repackaged and stored where protected from moisture, dirt, and excessive heat. Do not wrap material so that heat or moisture can become trapped. Ensure that items are level, fully supported, and have airflow between parts. Damage from improper storage is not considered shipping damage and is not covered by product warranties. Handle materials so as to protect materials, coatings, fabric and finishes during transportation and installation to prevent damage or staining.

It is the responsibility of the installer to meet or exceed all code and safety requirements, and to obtain all required building permits. These instructions are only a guide, and may not address every circumstance. The installer should determine and implement appropriate installation techniques for each situation. Structureworks shall not be held liable for improper or unsafe installations.

### Recommended Tools

The tools required for installation will vary depending on structure configuration and the hardware used. Review shop drawings to confirm drill bit sizes, socket sizes, and other project specific tools.

- Pencil
- 4' Level
- 8' Ladder (2)
- Framing Square
- Drill
- Caulk Gun
- Impact Driver w/ Phillips Bit
- Adjustable Wrench
- Tape Measure
- Socket Wrench w/ Sockets
- Compressed Air
- Hole-Cleaning Brush

### Required Materials

Depending on the configuration of the structure, additional materials such as ledger attachment hardware, silicone caulk, and anchoring epoxy may be needed. Review shop drawings for project specific requirements.

### Cleaning and Maintenance

Use a combination of Simple Green All-Purpose Cleaner and hot water with a soft bristle brush. Clean after installation and on an annual basis. For more difficult to clean marks, a Mr. Clean Magic Eraser can be used. Structural attachments should be inspected annually.

## Installation Sequence

This installation guide provides a step by step sequence for the installation of the structure. This guide covers only the structure, separate installation guides are provided for accessories and other products used in the installation of the structure. Ensure that you have all required installation guides before beginning the installation.

All structures are made to order and are provided with shop drawings. Shop drawings may contain additional information, details, or job specific instructions. Shop drawings take precedence over this installation guide.

## Layout

Layout all columns according to the shop drawings. Columns must be located precisely and variations in the height of the mounting surface must be accounted for by leveling each column. The structure will not install correctly if the columns are installed out of square or out of level from one another.

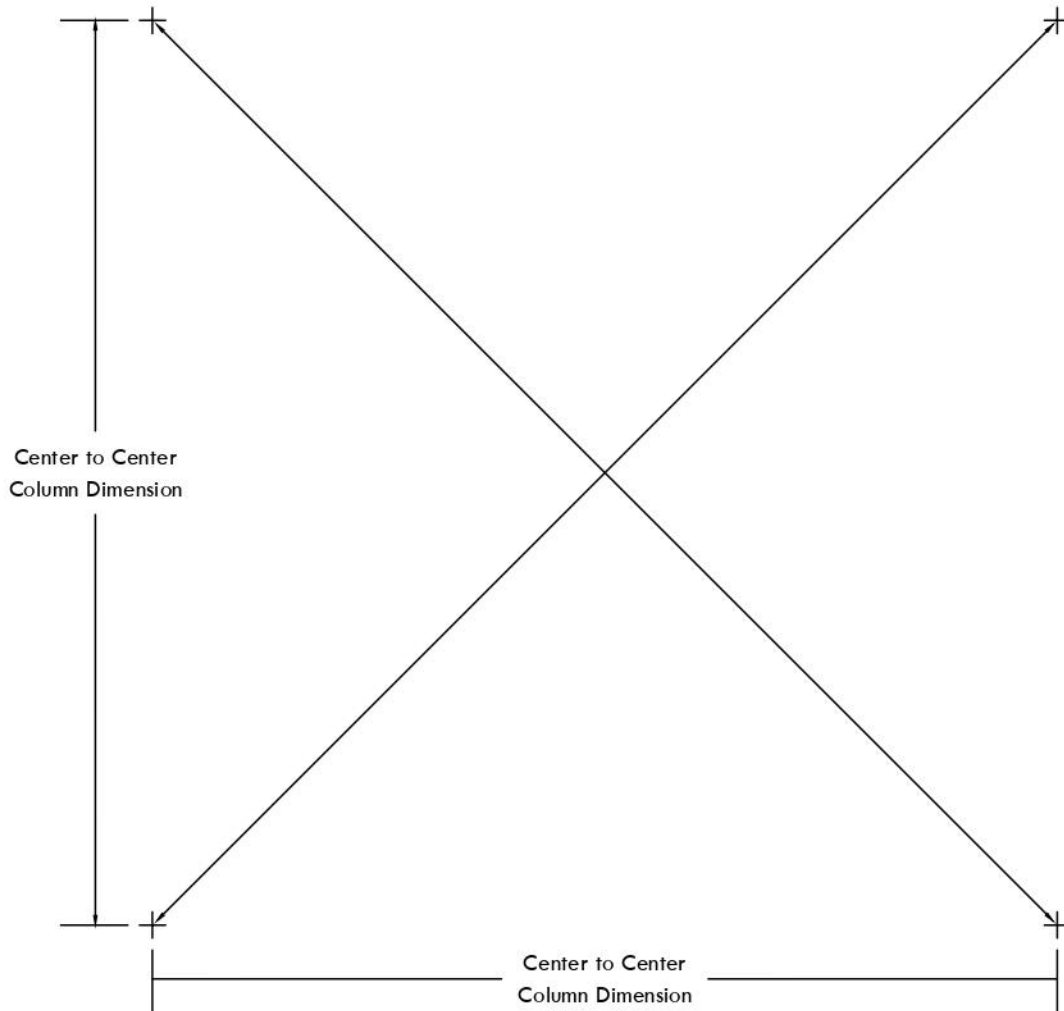

## Prepare for Column Installation - Concrete Mounting Surfaces

Drill the holes for the threaded rods and epoxy. The holes should be sized larger than the threaded rod diameter per the epoxy manufacturer's instructions. Clean the hole thoroughly

Fill the holes with epoxy per the manufacturer's instructions. Insert the threaded rods in a twisting motion to ensure epoxy flows into the threads of the rods. Ensure that the rods are inserted to the proper depth and are plumb.

## Prepare for Column Installation - Wood Mounting Surfaces

Install pressure treated wood blocking between the joists against the underside of the decking. Blocking should be a nominal thickness of 2" and wider than the framing mount plate.

Drill the holes for the threaded rods through the deck and wood blocking.

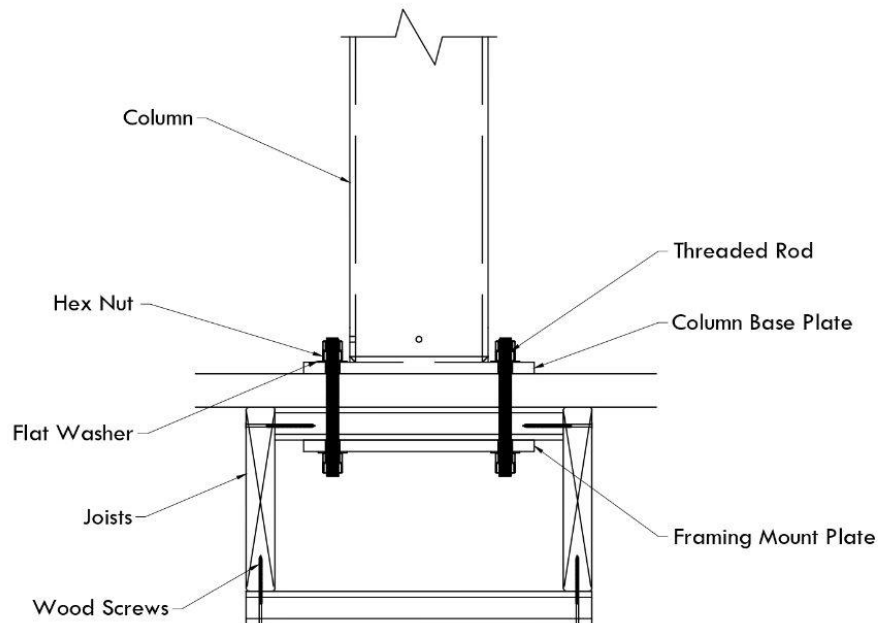
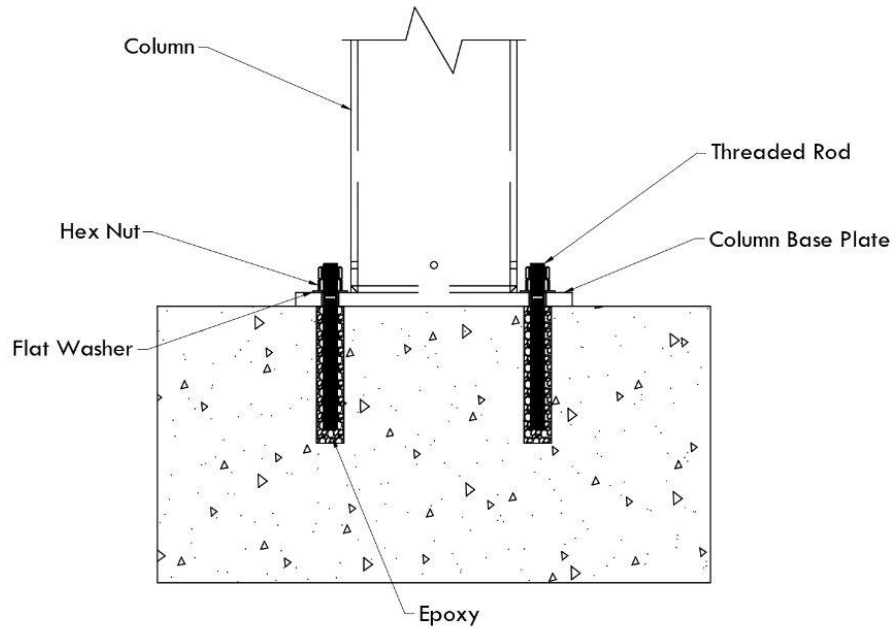

## Install Columns

Place the base plate cover over the top of the column and lower it to the ground.

Install internal brackets for the beams at the top of the columns. If the structure includes any integrations such as lighting or wiring for fans or heaters, be sure to make any connections or chase any wires and test the connections.

If the mounting surface is uneven, flat washers or non-shrink grout can be used to shim and level the surface. Wait to install flat washers and nuts to secure the threaded rods.

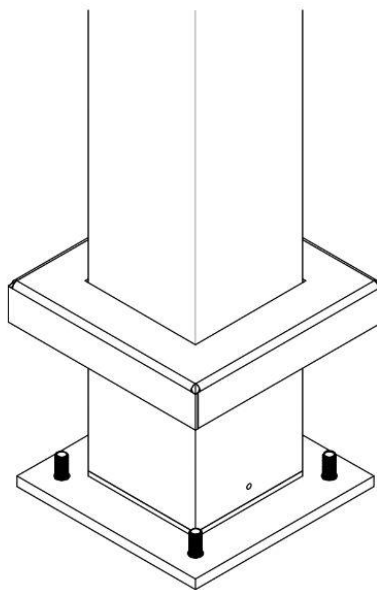
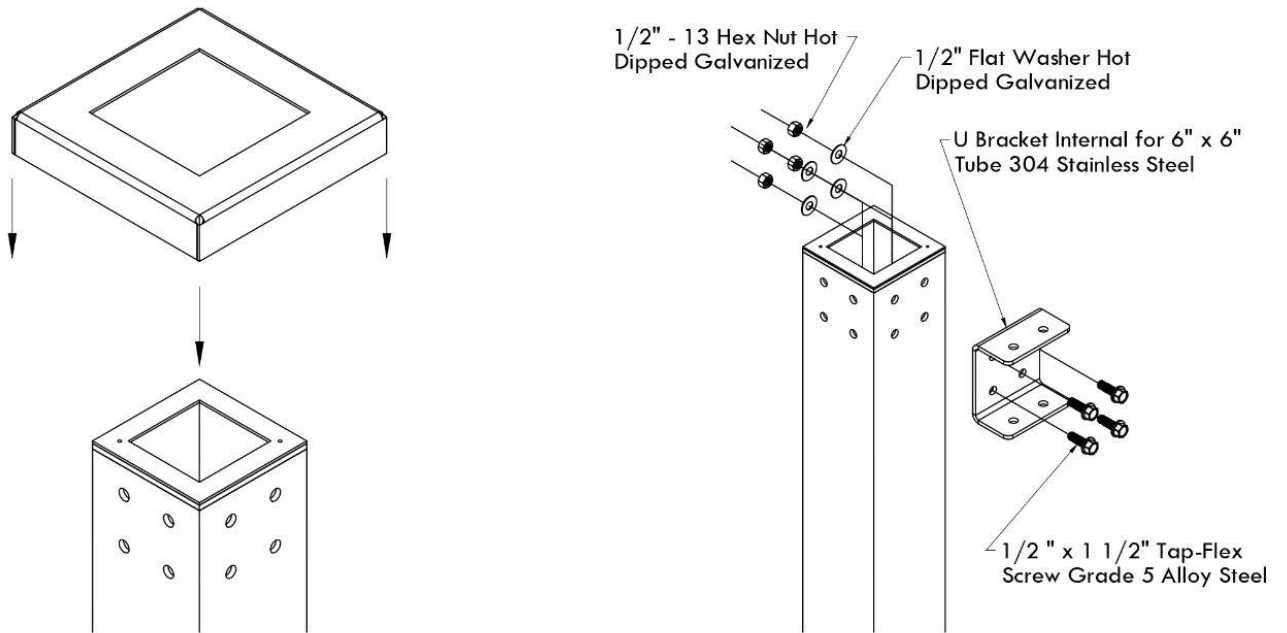

## Install Brackets and Ledger - Attached Structures Only

Install the internal brackets for the beams and rafters to the ledger. Mount the ledger to the host structure. Ensure that the ledger is mounted to structural components that can support the loads of the structure. Hardware for ledger attachment is not provided and will vary depending on mounting conditions.

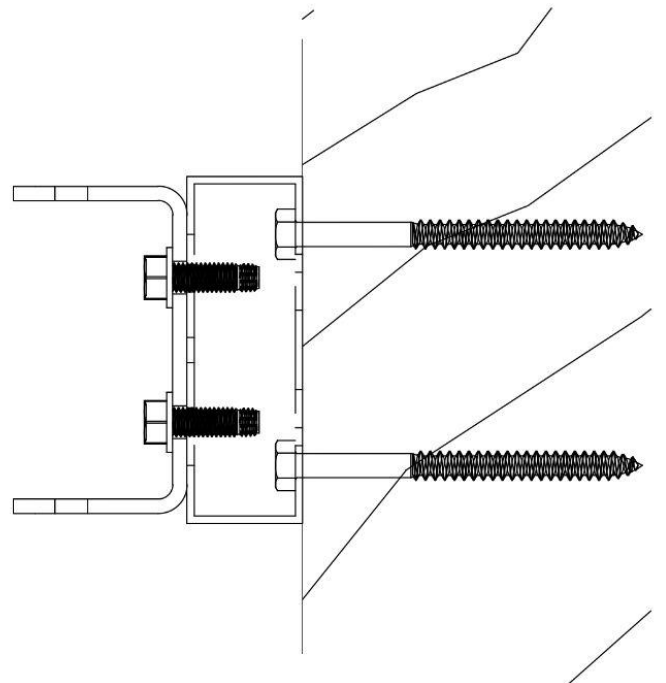
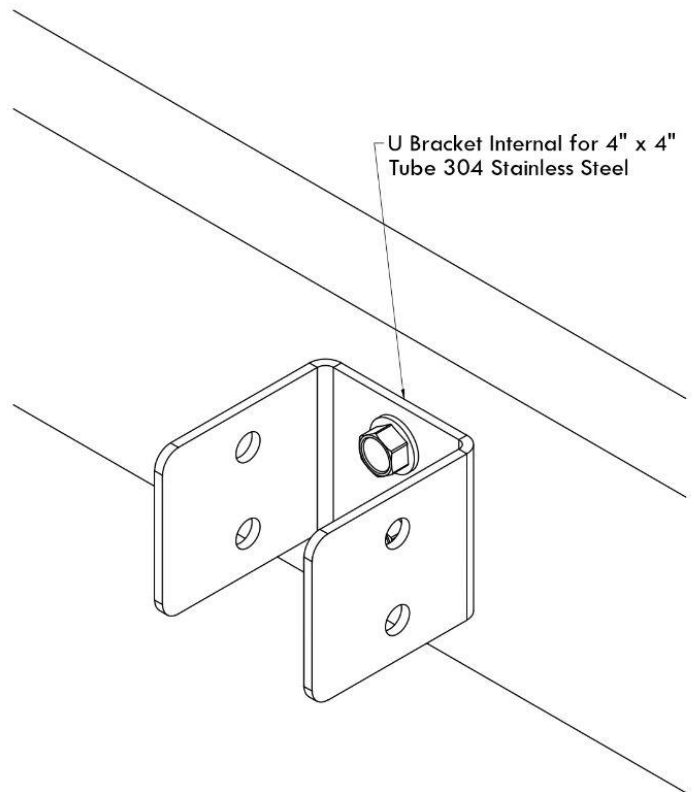
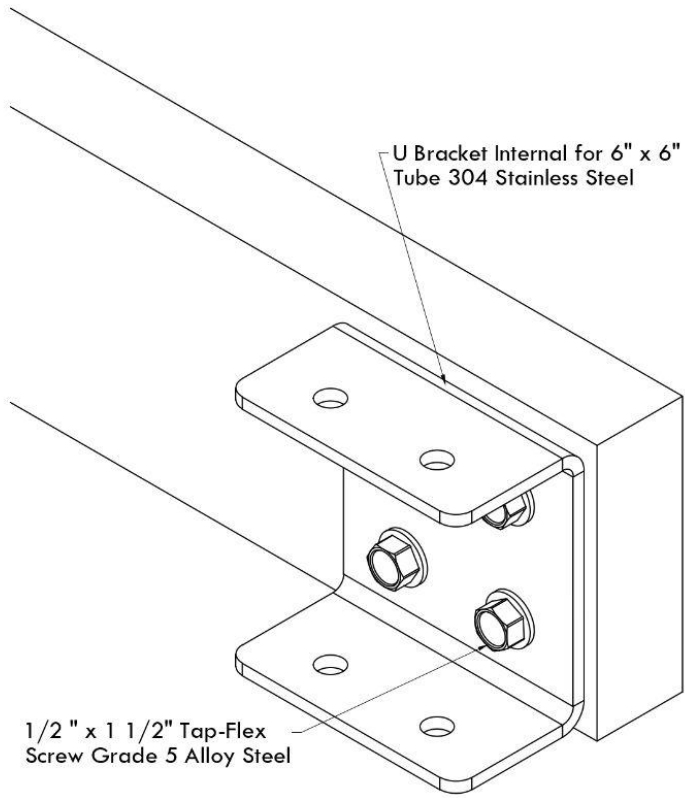

## Install Width Beams

Install the rafter brackets onto the width beam(s).

Attach a beam along the width of the structure to the supporting columns. It will be necessary to lean one of the columns away from the beam in order to slide the internal bracket mounted to the column into the end of the beam. Bolt the beam to the columns and tighten all hardware.

For freestanding structures, repeat this process for the other width beam.

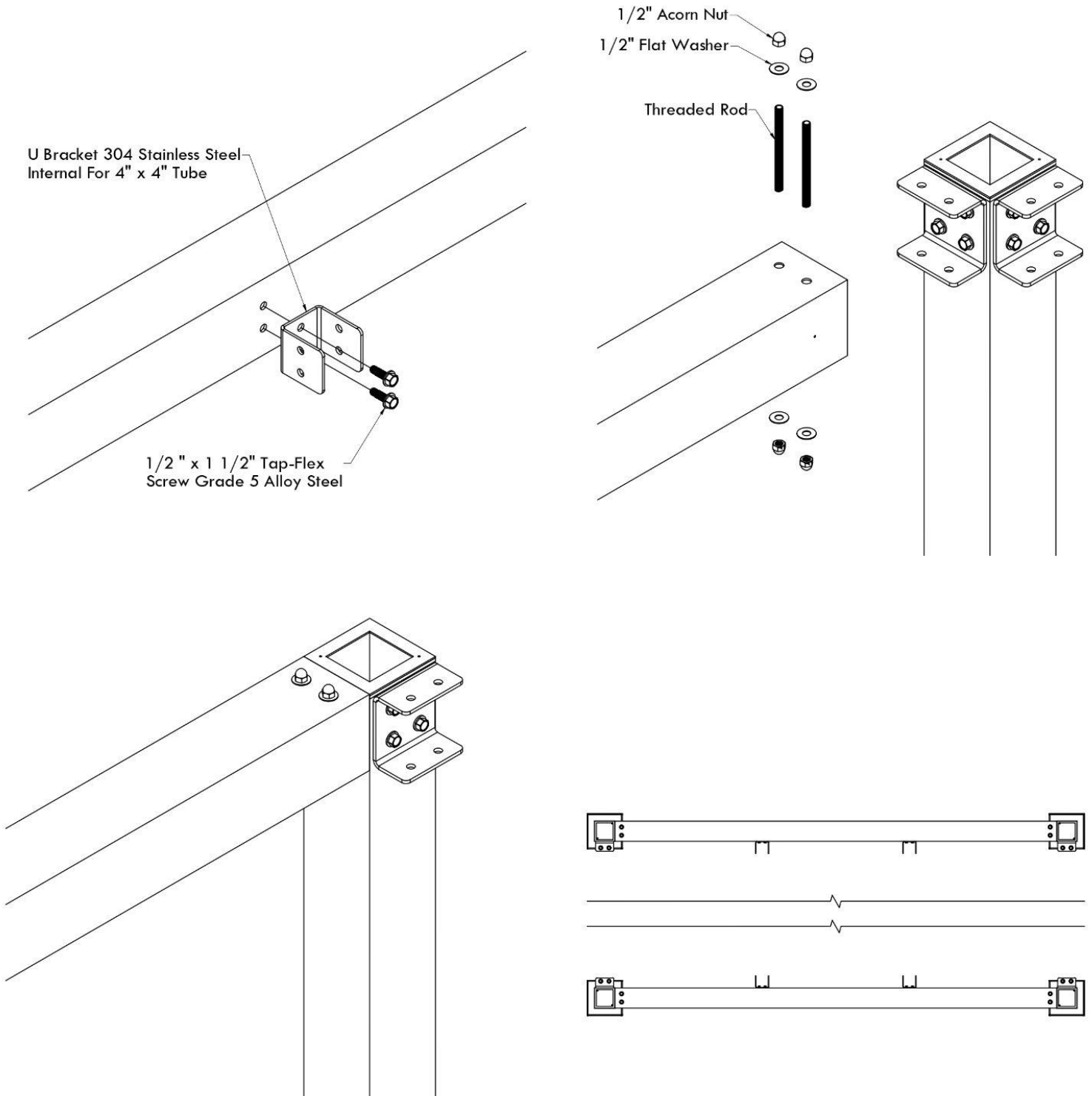

## Install Stringer Supports

Install the stringer supports onto the projection beams using screws. Ensure that the tops of the stringer supports, which have holes for the stringer hardware are facing up.

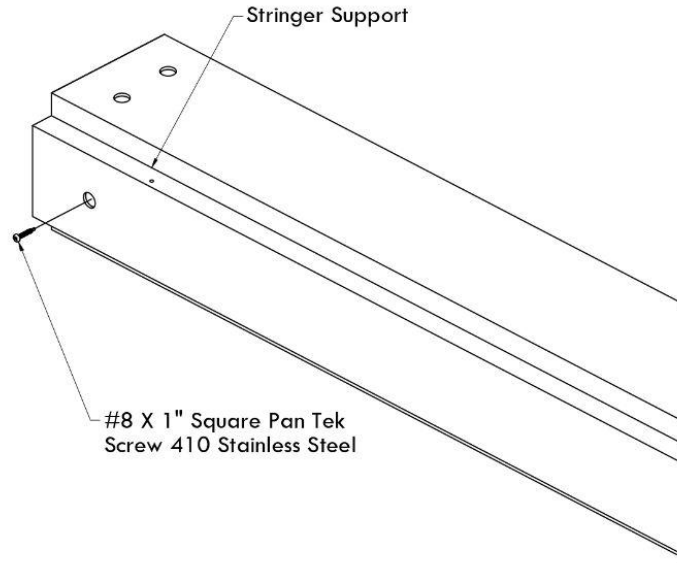

## Install Projection Beams and Rafters

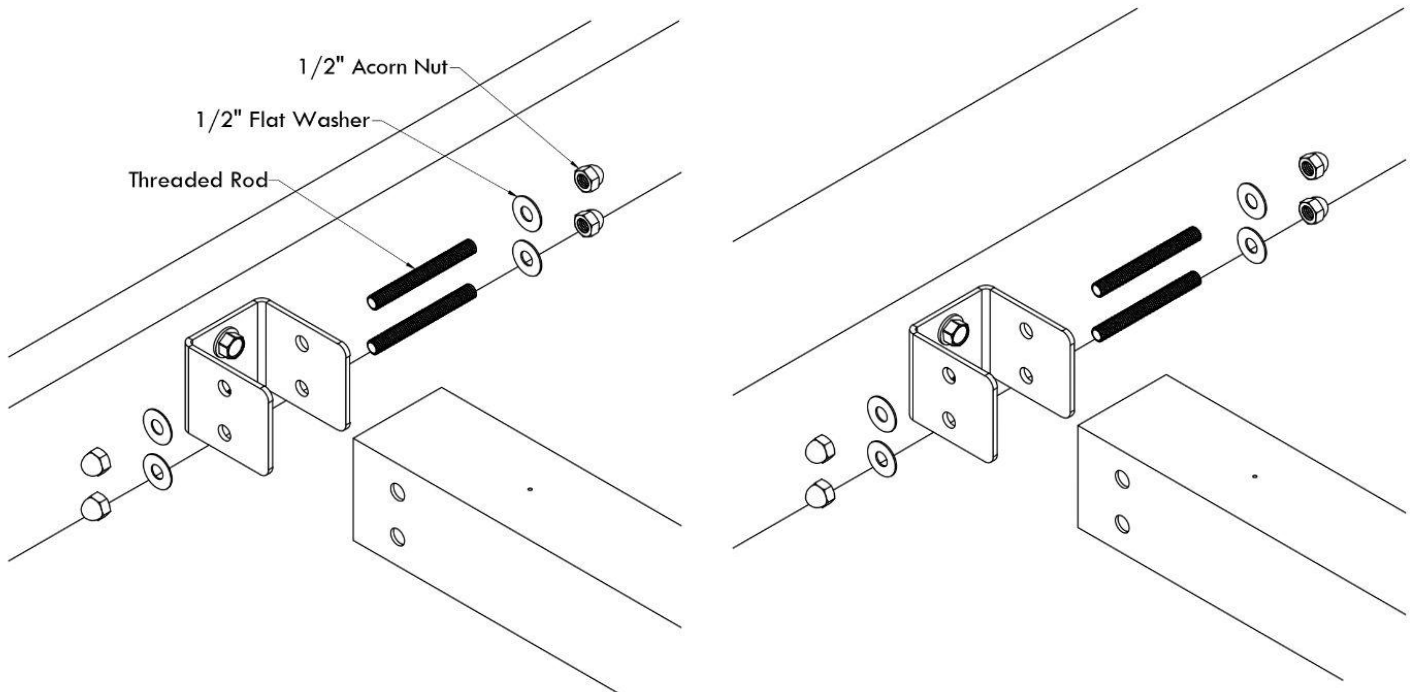

## Install Projection Beams and Rafters - Freestanding Structures

The projection beams and rafters must be installed in sequence from one side of the structure to the other. All of the components installed in this step will be bolted on one side of the structure while the unbolted ends are gradually slid onto the beam and rafter brackets and the width beam is slowly pulled closer to its final position. Ensure that the tops of the rafters, which have holes for the stringer hardware are facing up.

Once the projection beams and the rafters have been placed and bolted to the bracket on one end of the component, install the hardware on the other end of the component and fully tighten all beam and rafter connections.

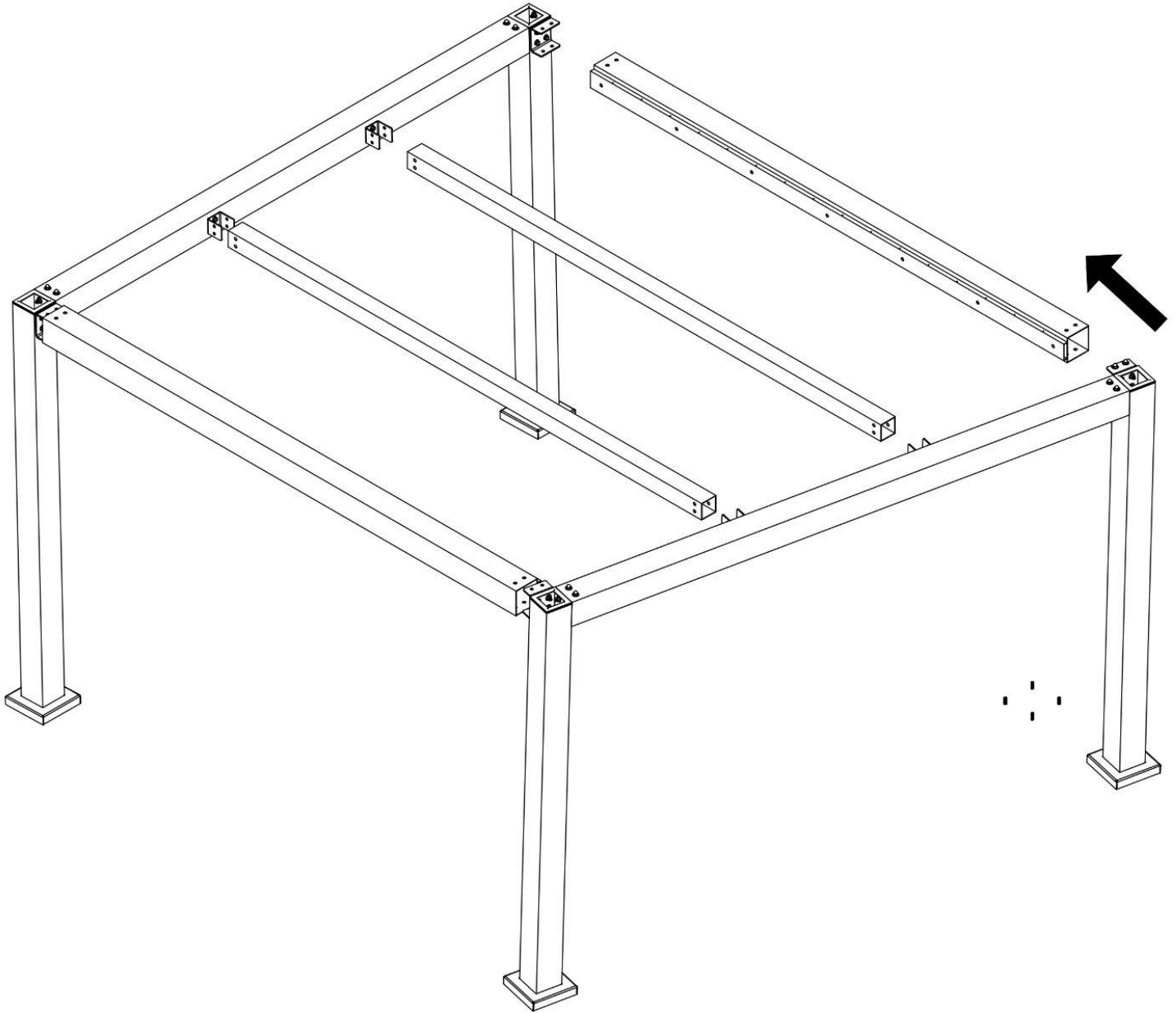



## Install Projection Beams and Rafters - Attached Structures

The projection beams and rafters must be installed in sequence from one side of the structure to the other. All of the components installed in this step will be bolted on one side of the structure while the unbolted ends are gradually slid onto the beam and rafter brackets and the width beam is slowly pulled closer to its final position. Ensure that the tops of the rafters, which have holes for the stringer hardware are facing up.

Once the projection beams and the rafters have been placed and bolted to the bracket on one end of the component, install the hardware on the other end of the component and fully tighten all beam and rafter connections.

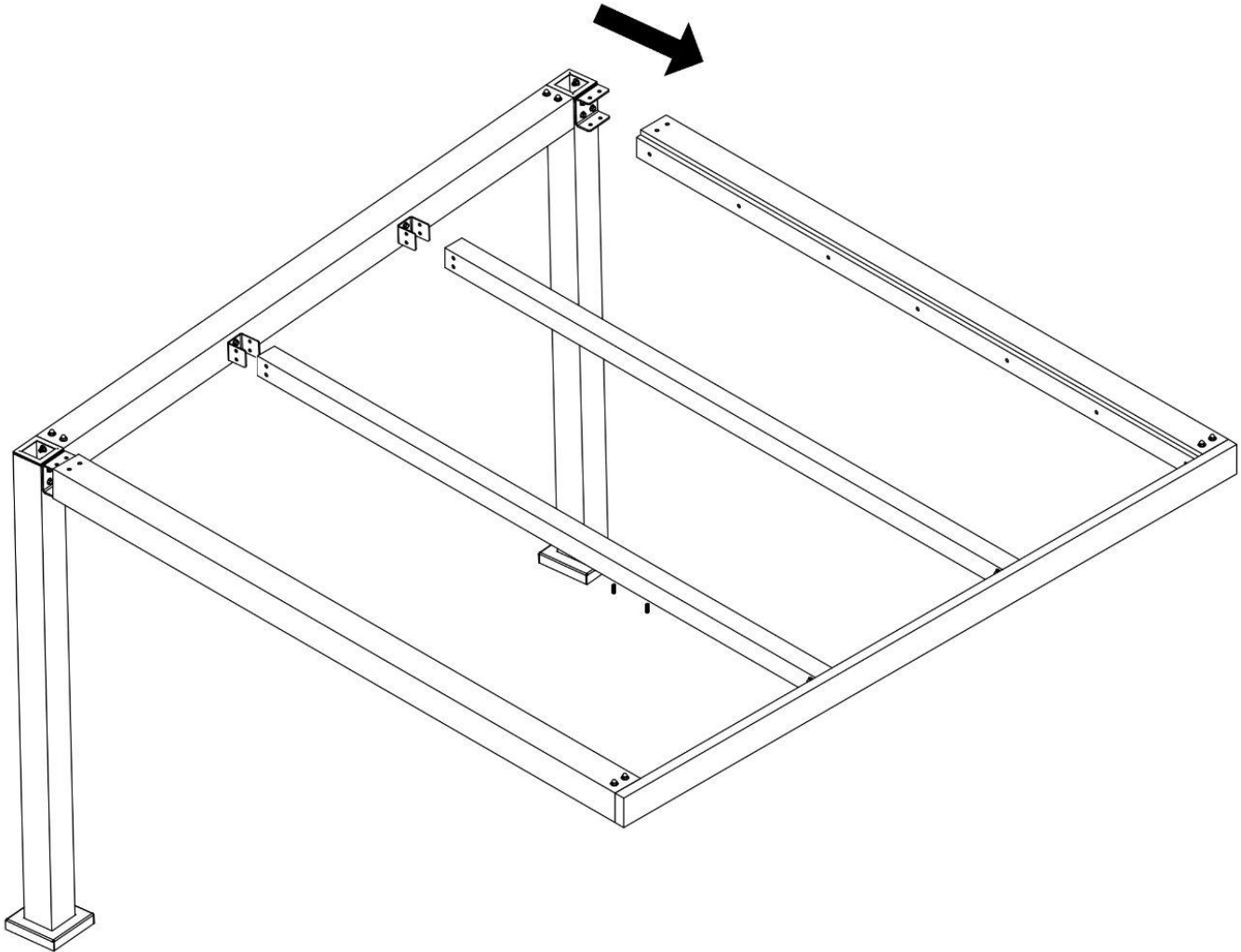

## Tighten Column Bolts

Confirm that the beams, rafters, and stringer supports are installed and bolted, that the beams are level, and that the columns are plumb.

Place flat washers and hex nuts onto the threaded rods at the base of the columns and tighten.

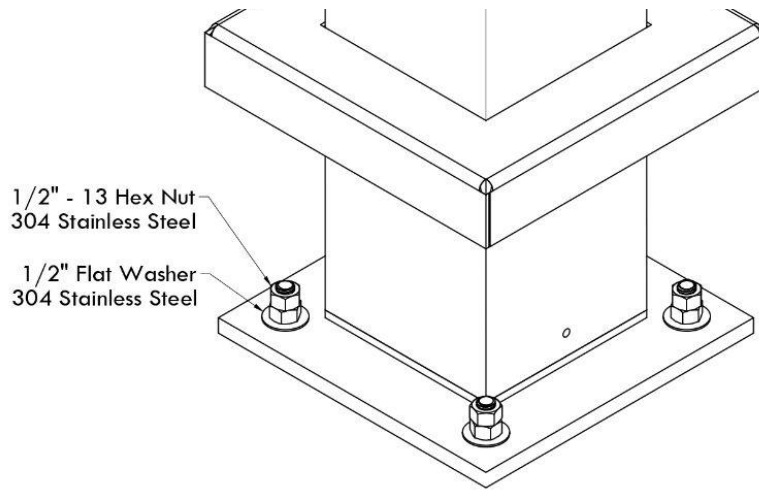

## Install Stringers

Install the stringer end caps with screws. Spliced stringers do not have end caps at the splice.

Position the stringers on top of the stringer supports and rafters. Align the stringers with the holes in the stringer supports and rafters and secure with screws.

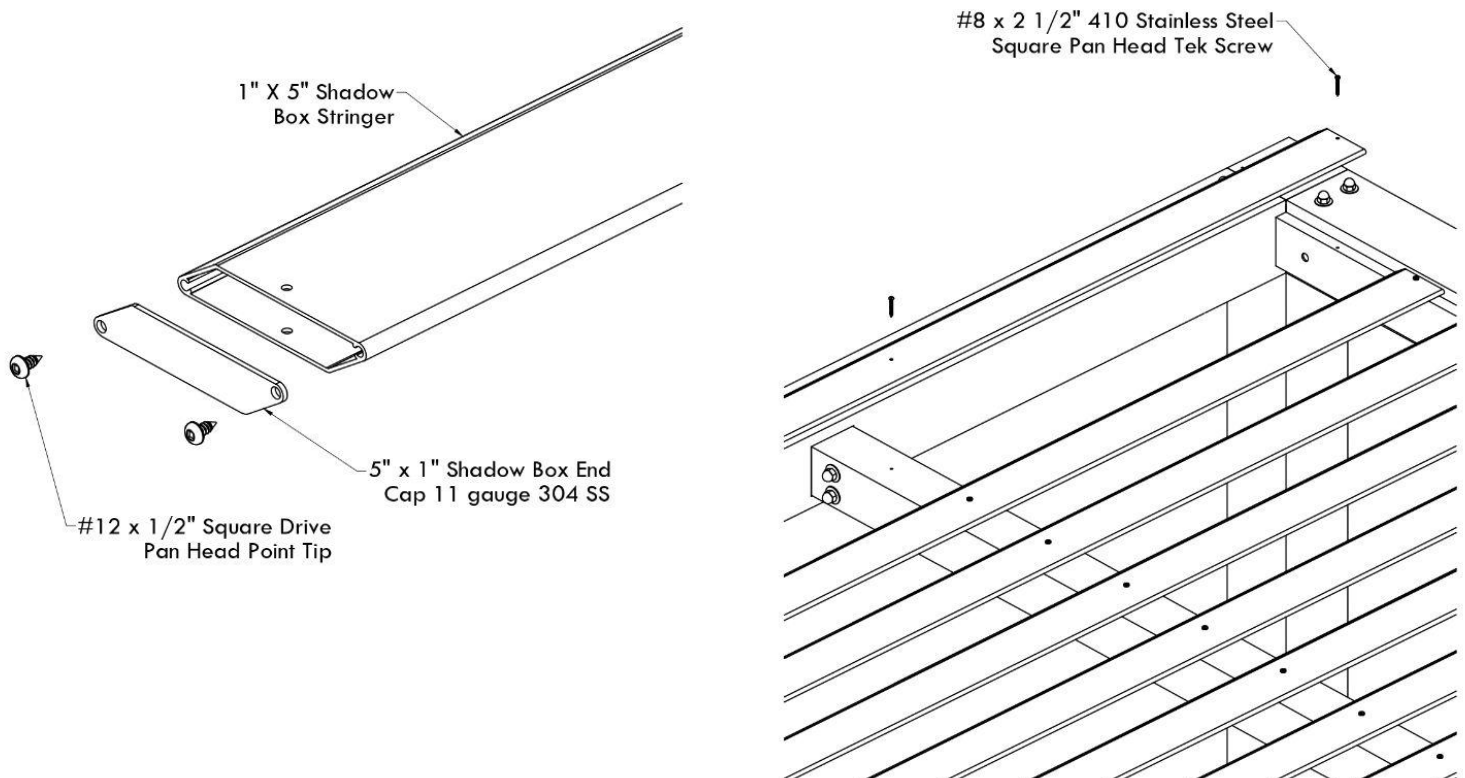

## Install Access Hole Covers & Hole Plugs

Install access hole covers on the tops of the columns using silicone sealant and screws.

Install hole plugs into the sides of the stringer supports and the face of the ledger, for attached structures.

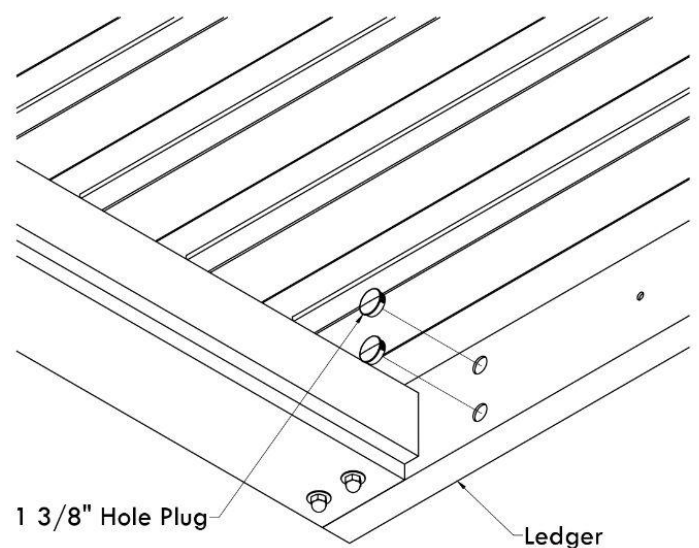
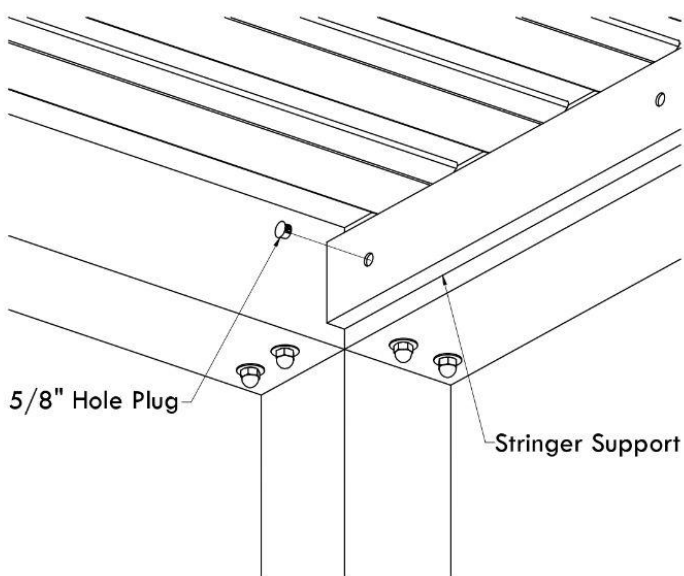
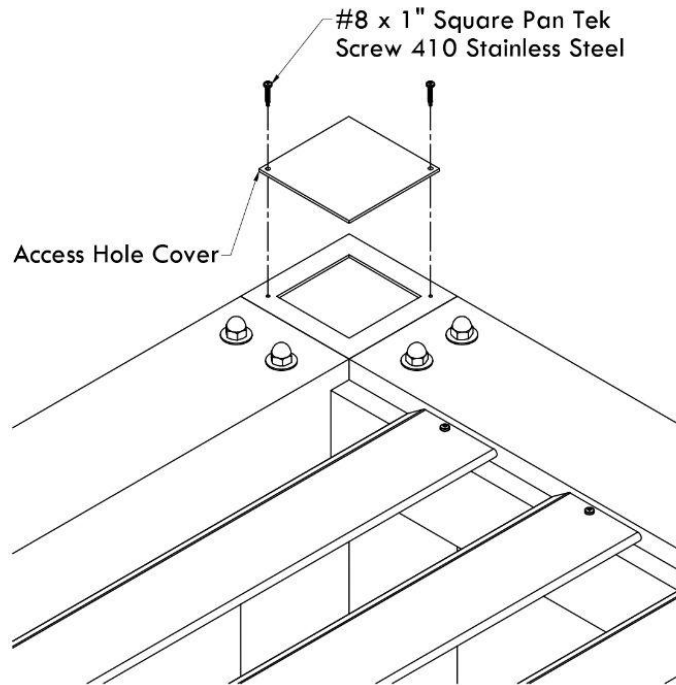

## Paint Touch-Up

All structures will require touch up over time and at completion of construction. Use extreme care when handling components. Touch up paint is provided. In the event of scratching or chipping, touch up the painted surface with the included brush. Apply light coats in order to allow the paint to flow and dry with a smooth finish.